

## Operating, Maintenance & Parts Manual

# EC Series

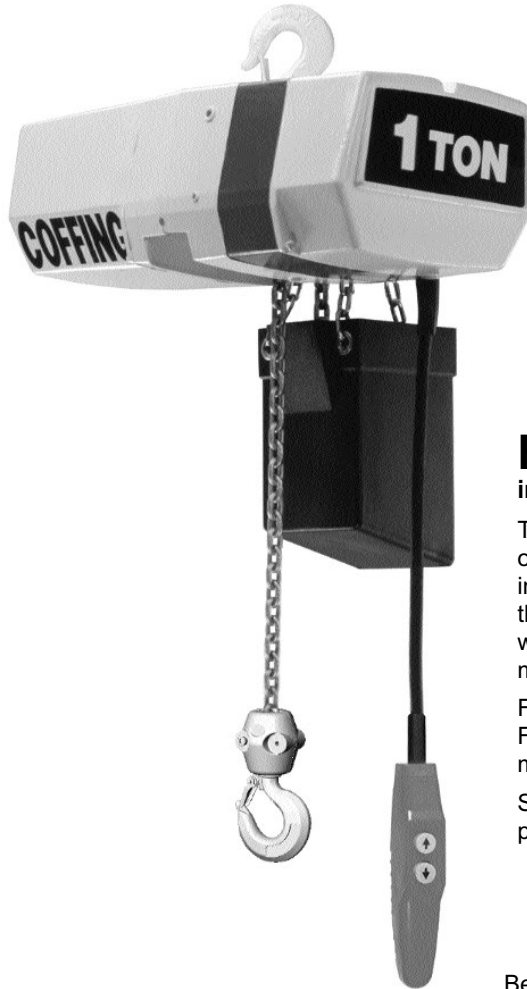

### Models

EC-0516	EC-2004
EC-0532	EC-2008
EC-0564	EC-2012
EC-1009	EC-2016
EC-1016	EC-4006
EC-1032	EC-4008
EC-6005	

For ECT models refer to this manual and CTA698-1 for trolley information.

**F**ollow all instructions and warnings for inspecting, maintaining and operating this hoist.

The use of any hoist presents some risk of personal injury or property damage. That risk is greatly increased if proper instructions and warnings are not followed. Before using this hoist, each operator should become thoroughly familiar with all warnings, instructions, and recommendations in this manual. Retain this manual for future reference and use.

Forward this manual to the hoist operator.

Failure to operate the equipment as directed in the manual may cause injury.

Should you have any questions regarding this product, please call Coffing Hoists at **(800) 477-5003**.

Before using the hoist, fill in the information below:

Model No. \_\_\_\_\_

Serial No. \_\_\_\_\_

Purchase Date \_\_\_\_\_

# COFFING®

## HOISTS

---

# Table of Contents

---

## SECTION 1 INTRODUCTION

1-1 General Information.....	2
1-2 Safety Standards.....	2
1-3 Hoist Construction and Features.....	2
1-4 Basic Hoist Data.....	2
1-5 Application Information.....	2
1-6 Warranty.....	2

## SECTION 2 INSTALLATION

2-1 Safety Notes.....	3
2-2 Hanging the Hoist.....	3
2-3 Power Supply Connection.....	3
2-4 Vent Plug.....	3
2-5 Chain Lubrication.....	3
2-6 Testing.....	3
2-7 Trolley Installation.....	3
2-8 Chain Container Installation.....	4

## SECTION 3 OPERATION

3-1 General.....	4
3-2 Safety Notes.....	4
3-3 Handling the Load.....	4
3-4 Overload Limiting Protection.....	5

## SECTION 4 INSPECTION

4-1 General.....	5
4-2 Frequent Inspection.....	5
4-3 Periodic Inspection.....	5
4-4 Load Brake Function Check.....	7
4-5 Chain Inspection.....	7
4-6 Hook Throat Opening.....	8

## SECTION 5 MAINTENANCE AND REPAIR

5-1 General.....	8
5-2 Limit Switch Adjustment.....	8
5-3 Motor Brake Adjustment.....	9
5-4 Top Suspension Removal and Replacement.....	9
5-5 Chain Replacement.....	9
5-6 Lubrication.....	10

## SECTION 6 TROUBLESHOOTING

6-1 General.....	12
------------------	----

## SECTION 7 WIRING

7-1 Voltage Conversion.....	14
7-2 Wiring Diagrams.....	14

## SECTION 8 ILLUSTRATED PARTS LISTS

8-1 General.....	17
8-2 How to Use the Parts List.....	17
8-3 How to Order Replacement Parts.....	17
FIGURE 8-1 Suspension Assembly Kits.....	18
FIGURE 8-2 Basic Hoist.....	19
FIGURE 8-3A Motor Parts (One Speed).....	21
FIGURE 8-3B Motor Parts (Two Speed).....	22
FIGURE 8-4A Controller Area (Single Phase).....	23
FIGURE 8-4B Controller Area (Three Phase).....	24
FIGURE 8-5 Transmission.....	25
FIGURE 8-6 Chaining Parts.....	27
FIGURE 8-7A Pushbutton (Single Speed Hoist).....	29
FIGURE 8-7B Pushbutton (Two Speed Hoist).....	30
FIGURE 8-8A Standard Limit Switch Parts.....	31
FIGURE 8-8B Long Lift Limit Switch Parts.....	32
FIGURE 8-9 Motor Brake Parts.....	33
FIGURE 8-10 Bottom Block Assemblies.....	35
FIGURE 8-11 Chain Container Parts.....	36

## SECTION 9 DO'S AND DO NOT'S

Electric and Air Powered Hoists "Do's and Do Not's".....	37
--	----

Warranty Repair Centers.....	41
------------------------------	----

Warranty.....	Back Cover
---------------	------------

---

# Introduction

## 1-1. General Information

This manual provides information for the safe operation and maintenance of Coffing® EC-1 Series Hoists. All persons operating or maintaining these hoists should be familiar with the information contained herein. Adherence to the precautions, procedures and maintenance practices described should ensure long reliable operation. Suggestions for improvements to this manual are solicited.

## 1-2. Safety Standards

All persons concerned with the installation, operation, inspection and maintenance of these hoists are urged to read American National Standard (ANSI) B30.16. That Standard contains valuable guidelines concerning practices designed to minimize hazards associated with the use of overhead hoisting equipment. ANSI B30.16 also contains maintenance programs and can be of significant assistance in maintaining compliance with OSHA regulations.

## 1-3. Hoist Construction and Features

Strong, lightweight aluminum alloy die castings provide a compact, protective enclosure for the mechanical and electrical components of Coffing EC-1 Series Hoists. Heat treated alloy steel gearing operates in an oil bath to provide the most reliable lubrication and effective heat dissipation.

EC-1 Series Hoists incorporate the following features:

- a. Overload limiting clutch.
- b. Completely independent mechanical and electrical brakes.
- c. Adjustable limit switches.
- d. Tough, nylon weatherproof pushbutton stations.
- e. Steel strain cable inside pushbutton cord.
- f. Transformer isolated, low-voltage pushbutton controls.
- g. Quick voltage conversion on dual-voltage units.

## 1-4. Basic Hoist Data

The basic hoist models covered by this manual are listed in Table 1-1.

TABLE 1-1 BASIC HOIST DATA			
Model No.	Rated Load (lb.)	Lift Speed at Rated Load (ft. per min.)	Motor HP
EC-0516	500	16	¼
EC-0532	500	32	½
EC-0564	500	64	1
EC-1009	1000	9	¼
EC-1016	1000	16	½
EC-1032	1000	32	1
EC-2004	2000	4	¼
EC-2008	2000	8	½
EC-2012	2000	12	1
EC-2016	2000	16	1
EC-4006	4000	6	1
EC-4008	4000	8	1
EC-6005	6000	5	1

## 1-5. Application Information

This hoist is intended for general industrial use in the lifting and transporting of freely suspended material loads within its rated load. Prior to installation and operation, the user should review his application for abnormal environmental or handling conditions and to observe the applicable recommendations as follows:

- a. **Adverse environmental Conditions.** Do Not use the hoist in areas containing flammable vapors, liquids, gases or any combustible dusts or fibers. Refer to Article 500 of *The National Electric Code*. Do not use this hoist in applications involving extended exposure to ambient temperatures below -10°F or above 130°F.
- b. **Lifting of Hazardous Loads.** This hoist is not recommended for use in lifting or transporting hazardous loads or materials which could cause widespread damage if dropped. The lifting of loads which could explode or create chemical or radioactive contamination if dropped requires fail-safe redundant supporting devices which are not incorporated into this hoist.
- c. **Lifting of Guided Loads.** This hoist is not recommended for use in the lifting of guided loads, including dumbwaiters and elevators. Such applications require additional protective devices which are not incorporated into this hoist. For such applications, refer to the requirements of applicable state and local codes, and the American National Safety Code for elevators, dumbwaiters, escalators and moving walks (ASME A17.1).

## 1-6. Warranty

Every hoist is thoroughly inspected and tested prior to shipment from the factory. Should any problems develop, return the complete hoist prepaid to your nearest Coffing Authorized Warranty Repair Station. If inspection reveals the problem is caused by defective workmanship or material, repairs will be made without charge and the hoist will be returned, transportation prepaid.

This warranty does not apply where: (1) deterioration is caused by normal wear, abuse, improper or inadequate power supply, eccentric or side loading, overloading, chemical or abrasive actions, improper maintenance or excessive heat; (2) problems resulted from repairs, modifications or alterations made by persons other than factory or Coffing Authorized Warranty Repair Station personnel; (3) the hoist has been abused or damaged as a result of an accident; (4) repair parts or accessories other than those supplied by Coffing are used on the hoist. Equipment and accessories not of the seller's manufacture are warranted only to the extent that they are warranted by the manufacturer. EXCEPT AS STATED HEREIN, COFFING MAKES NO OTHER WARRANTIES, EXPRESSED OR IMPLIED, INCLUDING WARRANTIES OF MERCHANTABILITY AND FITNESS FOR A PARTICULAR PURPOSE.

---

# Installation

---

## 2-1. Safety Notes

- a. Inspect the hoist for any evidence of shipping damage or loose parts.
- b. The supporting structure and load attaching devices should have a load rating at least equal to that of the hoist.
- c. This hoist is not suitable for use in uncovered outdoor locations or areas containing explosive dust, vapors or gases.
- d. The installation area must provide safe operating conditions for the operator, including sufficient room for the operator and other personnel to stand clear of the load at all times.
- e. In areas where slack chain hanging from the hoist may create a hazard, use a chain container (see Figure 2-2).

## 2-2. Hanging the Hoist

Hook mounted hoists can be used with a variety of trolleys or stationary hangers. It is recommended that a hand-gearred or motorized trolley be used when the pulling effort required to move the hoist exceeds 100 pounds or when the application requires frequent movement of the hoist.

- a. Make sure that the hook latch closes after hanging the hoist.
- b. The standard top hook is restrained from rotation by a plate and two screws. The hook can be made to swivel freely by removing the plate, or can be rotated 90° and fixed in that position.
- c. See Figure 2-1 for instructions on adjusting lug-mounted plain trolleys.
- d. Refer to Coffing Motorized Trolley Operating and Maintenance Instructions manual for motorized trolley installation instructions.

## 2-3. Power Supply Connection

- a. Disconnect power before making connections.
- b. Voltage supplied to the hoist should be within plus or minus 10% of the voltage specified for the hoist.  
Hoists are tagged at the factory with a tag indicating the voltage for which the hoist is wired. Standard single phase hoists are convertible from 115 to 230 volts. Standard single speed, three phase hoists are convertible from 460 volts to 230 volts. See the Wiring section (paragraph 7-1) for voltage conversion instructions.
- c. National Electrical Code (ANSI C1) and local electrical codes should be consulted and proper disconnects, branch circuit protectors, and wiring provided.
- d. Power cables furnished with the hoist have a green colored ground wire which must be securely connected to the electrical system ground.
- e. When installing a three-phase hoist, make only temporary connections at the power line. Push the "UP" button and observe the direction of the hook. If it raises, the phasing is correct and permanent connections may be made at the power line. If the load

block lowers when the "UP" button is pushed, release the button immediately since the limit switches will not operate to protect the hoist from over-travel. Reverse the red and black wires at the power line connection to correct the hook direction.

### CAUTION

**Do not change connections in the hoist or the pushbutton assembly.**

## 2-4. Vent Plug

A pressure relief plug (Item 24, Figure 8-2) is provided which will vent excess pressure from the transmission housing.

## 2-5. Chain Lubrication

The hoist chain should be liberally oiled before placing the hoist into operation. For lubrication instructions, see paragraph 5-6.a.

## 2-6. Testing

- a. Before placing the hoist into operation, check for proper limit switch operation. Push the "UP" button and verify that the hook block stops at least 2 inches from the bottom of the hoist. Run the hoist down to its lower limit. At least 12 links of chain should remain on the slack end. If either switch is not correct, adjust according to the procedure outlined in paragraph 5-2.

### NOTE

**The upper and lower limit switches are factory set to provide the maximum allowable hook travel. This travel adjustment should not be increased. However, the switches may be adjusted to stop the hook sooner at either end of its travel.**

- b. Attach a light load to the hook and check the hoist for proper operation. The load should stop without noticeable drift when the pushbutton is released. Increase the load to near rated load. The hoist should still lift the load without hesitation and stop with no more than one inch drift.

## 2-7. Trolley Installation

For Lug Mount and Plain Trolley configurations refer to included manual part number CTA698-1.

For Motorized Trolley configurations refer to included manual part number.

## 2-8. Chain Container Installation

- Operate hoist in "down" direction until it is stopped by the limit switch. Disconnect the slack end of the chain from the hoist by using a small screwdriver to slide the spring-loaded pin to the left. At least 8 inches of chain should hang from the hoist. If less than 8 inches of slack chain is present, readjust the lower limit switch using the procedures detailed in paragraph 5-2.
- Slide the spring-loaded pin aside and slip the mounting arm into the slot until the pin fits through the hole in the plate (see Figure 2-2). Be sure the pin passes completely through the plate and into the opposite housing.
- Use the two hex washer head screws provided to fasten the two remaining hanger chains into the notches on the lower edges of the hoist housings.
- Be sure the end of the chain is started into the container. Run hoist up until the hook block is even with the bottom of the chain container.
- Reset upper limit switch at this position (see procedure, paragraph 5-2) to prevent the possibility of raising a load into the chain container.

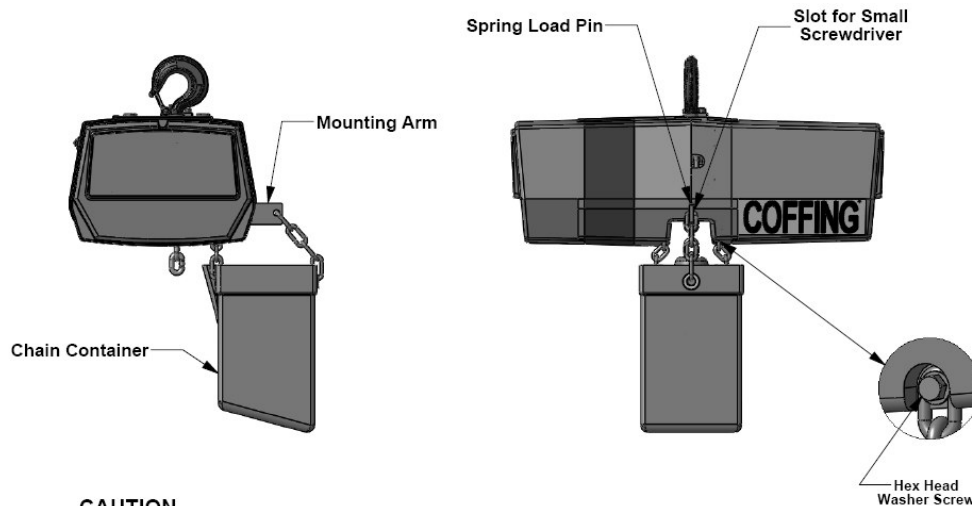

**CAUTION**  
Short edge of chain container body must be mounted toward hoist (as shown above).

## Operation

### 3-1. General

This section presents information concerning the proper operation of the Coffing Electric Chain Hoist. It is not intended to serve as a handbook on rigging. Rigging, the process of moving heavy loads using mechanical devices, requires special knowledge and equipment. For information on the safe use of slings and similar rigging gear, users are urged to consult a textbook on rigging.

### 3-2. Safety Notes

- Inspect the hoist for any sign of loose, broken or malfunctioning parts (see Section 4). Any malfunctioning hoist should be tagged as "Out of Order" and removed from service until the defect is corrected.
- Before starting the hoist, the operator should be certain that all personnel are clear.
- Do not lift more than the rated load of the hoist.
- Do not lift people or loads over people.
- Avoid jogging controls or quick reversal of suspended loads.
- Do not leave a suspended load unattended.

- The operator should have a clear view of the load anytime it is moving and should be sure that the load does not contact any obstructions.
- Read ANSI B30.16 Safety Standard for Overhead Hoists.

### 3-3. Handling the load

- Align hoist directly over the load. Avoid side pull.
- The hoist chain should not be wrapped around the load. Use proper slings.
- Be sure there are no twists in the load chain as it enters the hoist.

#### Caution

**This condition should be constantly checked on double or triple chain hoists because it is possible for the load block to be "capsized" or flipped over one or more times, putting twist in the chain. The presence of twist may not be obvious when the hook block is in the lowered position but can cause serious chain binding when the hook block is in its fully raised position.**

- d. Bring the hook into engagement with the load and make sure it is well seated before proceeding to lift the load. On multiple reeved hoists, be sure that the load is equalized on all supporting chains.
- e. Lift the load just clear of its supports and stop the hoist to check for proper brake operation.
- f. Avoid letting the hook or load swing excessively while moving a trolley suspended hoist.

### 3-4. Overload Limiting Protection

This hoist is equipped with a factory-calibrated overload limiting clutch, which permits lifting loads within rated

capacity and prevents lifting excessive loads which could damage the hoist. If the load exceeds the lifting capability of the overload clutch, the hoist will not lift the load, but the motor will run as long as the "UP" button is pressed. Repeated attempts to lift an excessive load will overheat the overload clutch and cause permanent damage to the clutch.

#### CAUTION

**The overload limiting clutch is an emergency protection device. It should not routinely be used to measure the maximum load to be lifted.**

---

## Inspection

---

### 4-1. General

A scheduled inspection routine should be established for this hoist based upon severity of use and environmental conditions. Some inspections should be made frequently (daily to monthly) and others periodically (monthly to yearly). It is suggested that an Inspection and Maintenance Check List and an Inspector's Report similar to those shown in Figures 4-1 and 4-2 be used and filed for reference. All inspections should be made by a designated inspector. Special inspections should be made after any significant repairs or any situation causing suspicion that the hoist may have been damaged. Any hoist which has been removed from service for an extended time should receive an inspection as described under Periodic Inspections. ANSI B30.16, Safety Standard for Overhead Hoists, provides guidelines for hoist operation and inspection.

#### CAUTION

**Any unsafe condition disclosed by any inspection must be corrected before operation of the hoist is resumed.**

### 4-2. Frequent Inspection

- a. Check pushbutton station, brake and limit switches for proper operation.
- b. Check hooks for deformation, chemical damage or cracks. Bent hooks or hooks damaged from chemicals, deformation, cracks or having excessive throat opening (see paragraph 4-6) should be replaced. Visible deformation of any hook may be evidence of hoist abuse and overloading and indicates that a thorough inspection of the complete hoist should be made.
- c. Check that the bottom hook swivels freely.
- d. Check for missing, bent or otherwise damaged hook latches.
- e. Check pushbutton and power cord for cuts or other damage.

### 4-3. Periodic Inspection

The exact period for the following inspections will depend on the anticipated severity of hoist use. Determination of this period should be based on the user's experience. It is recommended that the user begin with a monthly inspection and extend the periods to quarterly, semiannually, or annually, based on his monthly inspection experience.

- a. Clean hoist of any dirt or foreign material. Inspect bottom block for accumulation of debris.
- b. Perform all frequent inspections listed above, c. Check for loose bolts, screws and nuts.
- d. Check housings, load block, and other parts for wear, corrosion, cracks or distortion. Check for abnormal openings between housing sections.
- e. Check motor brake for worn discs, oil contamination or excessive clearance (see paragraph 5-3).
- f. Check mechanical load brake function (see Figure 4-3).
- g. Inspect the entire length of chain for gouges, nicks, weld spatter, corrosion, distortion and wear. See CHAIN INSPECTION, paragraph 4-5.
- h. Inspect hooks and suspension parts for cracks, distortion or extreme wear.
- i. Inspect hooks for cracks using magnetic particle, dye penetrant or other crack detecting methods.
- j. Check limit switch set points and reset if necessary (see paragraph 5-2).
- k. Inspect all wiring for defective insulation, and check to be sure all electrical connections are tight. Check motor reversing contactor or relay for burned contacts.
- l. Inspect for oil leaks. Check oil level.
- m. Inspect for missing or illegible capacity or warning labels.
- n. Inspect the supporting structure for continued ability to support the hoist rated load.

## Figure 4-2. Recommended Inspection List

Manufacturer: \_\_\_\_\_ Original Installation Date: \_\_\_\_\_

Location: \_\_\_\_\_ Manufacturer's Serial No.: \_\_\_\_\_

Item	Frequency of Inspection			Possible Deficiencies	OK	Action Required
	Frequent		Periodic			
	Daily	Monthly	1-12 Mo.			
Operating Controls	*	*		Any deficiency causing improper operation		
Limit Switches	*	*		Any deficiency causing improper operation. Pitting or deterioration		
Disc (Motor) Brake	*	*		Slippage or excessive wear. Glazing, contamination or excessive wear		
Load Brake (Mechanical)				Failure to support load with disc brake open (see paragraph 4-3.1)		
Hooks	*	*	**	Excessive throat opening, bent or twisted more than 10°, damaged hook latch, wear, chemical damage, worn hook bearing or cracks (use dye penetrant, magnetic particle or other suitable detection method)		
Suspension Lug (If Used)			**	Cracks, excessive wear or other damage which may impair the strength of the lug. Cracks (use dye penetrant, magnetic particle or other suitable detection method)		
Chain	*	*	*	Inadequate lubrication, excessive wear or stretch, cracked, damaged or twisted links, corrosion or foreign substance		
Hook and Suspension Lug Connections			*	Cracks, bending, stripped threads, loose mounting screws		
Pins, Bearings, Bushings, Shafts, Couplings, Chain Guides			*	Excessive wear, corrosion, cracks, distortion		
Nuts, Bolts & Rivets			*	Looseness, stripped and damaged threads, corrosion		
Sheaves			*	Distortion, cracks and excessive wear. Build up of foreign substances		
Housings & Load Block			*	Cracks, distortion, excessive wear. Internal build up of foreign substances		
Wiring & Terminals			*	Fraying, defective insulation		
Contact Block, Magnetic Hoist Control Switch, Other Electrical Apparatus			*	Loose connections, burned or pitted contacts		
Supporting Structure and Trolley (If Used)			*	Damage or wear which restricts ability to support imposed loads		
Nameplates, Decals, Warning Labels			*	Missing, damaged or illegible		
Transmission Lubricant			*	Low level. Requires changing.		

NOTE: Refer to Maintenance and Inspection Sections of the Hoist Maintenance Manual for further details.

**FREQUENCY OF INSPECTION:**

Frequent - Indicates items requiring inspections daily to monthly. Daily inspections may be performed by the operator if properly designated.  
Periodic - Indicates items requiring inspection monthly to yearly. Inspections to be performed by or under the direction of a properly designated person. The exact period of inspection will depend on frequency and type of usage. Determination of this period will be based on the user's experience. It is recommended that the user begin with a monthly inspection and extend the periods to quarterly, semi-annually or annually based on his monthly experience.





b. Inspect each link for wear to the diameter of the link (see Figure 4-4). The nominal link diameter is 0.250" for chain on models up to EC-2008 and 0.281" for models EC-2012 and above. If the diameter of any link of 0.250" chain is worn to less than 0.200", or the diameter of any link of 0.281" chain is worn to less than 0.225", the entire chain must be replaced.

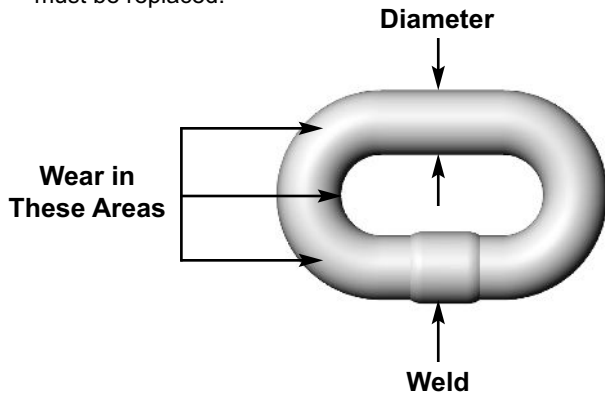

c. 1.) Check the chain for overall wear or stretch by selecting an unworn, unstretched length of chain (at the slack end, for example). Let the chain hang vertically with a light load (about 20 lbs.) on the chain to pull it tight. Use a large caliper to measure the outside length of a convenient number of links (about 12 inches). Measure the same number of links in a used section of chain and calculate the percentage increase in length of the worn chain.  
2.) If the length of the worn chain is more than 1½% longer than the unused chain (.015" per inch of chain measured), then the chain should be replaced. If the chain is worn less than 1½%, check it at several more places along its length. If any section is worn more than 1½%, the chain should be replaced.

d. The chain used in this hoist is accurately calibrated to operate over the load sprocket and is very carefully heat treated for maximum wear life and strength.

**WARNING**

1. Do not weld or join hoist load chain
2. Do not substitute another manufacturer's chain in this hoist.
3. Damage or wear, beyond the stated limits, to any portion of the chain requires that the entire length be replaced.

**4-6. Hook Throat Opening**

Use Table 4-1 (below) to check hook throat opening.

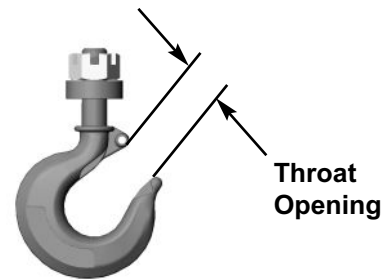

**Table 4-1. Hook Throat Opening**

Hoist Load Rating (ton)	Top Hook* (in.)	Bottom Hook* (in.)
¼, ½, & 1	1 5/16	1 3/16
2	1 5/16	1 5/16
3	1 17/32	1 17/32

\*Figures given are for hook with latch. Add 1/16" if measured without hook latch.

## Maintenance and Repair

**5-1. General**

This section provides instructions for the most common routine maintenance and adjustments. Major repairs are not within the scope of this manual and should be referred to qualified service facilities.

**SAFETY NOTE**

**Always remove load and disconnect hoist from power supply before removing end covers or making repairs.**

**5-2. Limit Switch Adjustment**

Limit switches are provided to protect the hoist against damage resulting from overtravel. For easy identification the upper (No. 2, Figure 5-1) and lower (No. 3, Figure 5-1) limit switch adjusting nuts are colored brass and zinc respectively. Each limit switch nut has ten slots for adjustment, and the increment of adjustment is such that one slot is equivalent to one link of chain travel. Care should be exercised when adjusting either limit of travel. When a geared type limit switch is furnished (long lift hoists) each adjustment is equal to 3 links of chain, or 30 links per revolution.

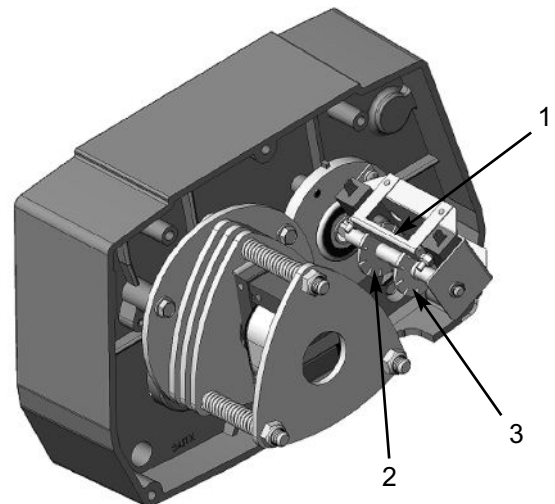

**FIGURE 5-1. LIMIT SWITCH ADJUSTMENT**

#### a. Adjusting Upper Limit (Brass Nut)

- 1.) Carefully raise the load block to a point where its top is 2" or more from the hoist housing.
- 2.) DISCONNECT POWER from the hoist and remove the short end cover.
- 3.) With a screwdriver, pry the spring guide plate (No. 1, Figure 5-1) out of the slots in the colored limit switch nuts (No. 2 and 3).
- 4.) Turn the slotted brass nut (No. 2) toward its limit switch until the switch clicks.
- 5.) Release the spring guide plate and be sure it snaps back into the slots in both nuts. Do not disturb the other slotted nut if it has been previously set.
- 6.) replace the short end cover and reconnect power to the hoist.
- 7.) Carefully raise the load block to its upper limit and observe to see if it stops automatically at the desired point. Do not allow the load block to run into the hoist housing. The stopping point should be at least 2" below the hoist housing.

#### b. Adjusting Lower Limit (Zinc Nut)

- 1.) Carefully lower the load block to a point where at least 12 links of slack chain hang down from the hoist housing.
- 2.) DISCONNECT POWER from the hoist and remove the short end cover.
- 3.) Adjust the zinc limit switch nut in the same manner described above for the brass nut.
- 4.) Replace the short end cover and reconnect power to the hoist.
- 5.) Carefully lower the load block to its lower limit and observe to see if it stops automatically at the desired level. Do not run chain out of hoist or allow the slack end loop to become tight against the hoist housing. At least 12 links of slack chain should hang from the hoist.

#### NOTE

If upper and lower limits are not operating satisfactorily, repeat adjustment.

### 5-3. Motor Brake Adjustment

When properly adjusted, the multiple disc motor brake should release promptly, operate without noticeable chatter, and stop the load with no more than one inch of drift. If the hoist hesitates to lift the load promptly when the pushbutton is depressed, the brake should be adjusted per the following procedure.

- a. Remove any load and DISCONNECT POWER from hoist.
- b. Remove the short end cover.
- c. Referring to Figure 4-2, check the gap between armature (A) and frame (B). The correct gap is .015".
- d. Adjust the gap by turning the three lock nuts (F) and check with a feeler gauge to be sure the gap is the same on both ends of the solenoid.

#### CAUTION

Be sure the bottom of the armature does not touch the splined adapter (H). As wear occurs, the original clearance will be reduced. When this clearance is gone, THE BRAKE DISCS MUST BE REPLACED.

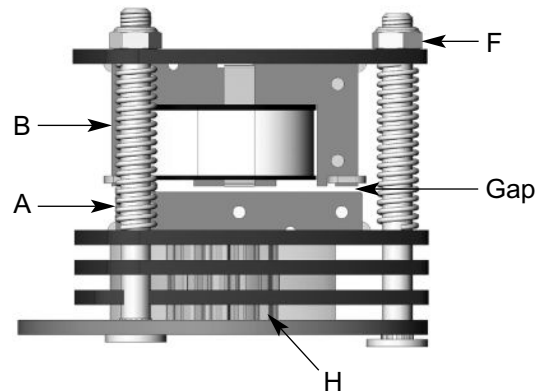

FIGURE 5-2. MOTOR BRAKE ADJUSTMENT

- c. Replace short end cover and reconnect power. If the brake still chatters or is hesitant to release, refer to Section 6, Troubleshooting.

### 5-4. Top Suspension Removal and Replacement

A number of different top suspension assemblies are available to accommodate different methods of hanging the hoist. If it should be necessary to change top suspensions, proceed as follows:

- a. DISCONNECT POWER from hoist and move the hoist to a safe working area. If necessary, remove trolley and/or rotate suspension lug to gain access to the socket head cap screws bolting the top suspension yoke to the frame of the hoist.
- b. Remove socket head screws (7/16" hex) and lift out the suspension assembly.
- c. Install new suspension assembly and tighten socket head screws to 75 ft-lbs of torque.

#### NOTE

Due to the off-center hook or lug hole, the suspension yoke can be installed in the hoist in two different ways. With the hoist level, the hook or lug must always be directly over the bottom hook. Refer to Figure 5-4 for the proper yoke orientations for single, double and triple chain hoists.

### 5-5. Chain Replacement (Old chain still in hoist)

Refer to Figure 5-4, Chaining and Suspension Diagrams, and proceed as follows:

- a. Run the load block up to its top limit.
- b. DISCONNECT POWER from the hoist and remove the short end cover.
- c. With a screwdriver, push the spring guide plate (No. 1, Figure 5-1) out of the slots in the limit switch nuts. Turn the brass slotted nut (2) back to about the center of the threaded screw. DO NOT DISCONNECT THE WIRES FROM THE LIMIT SWITCHES.

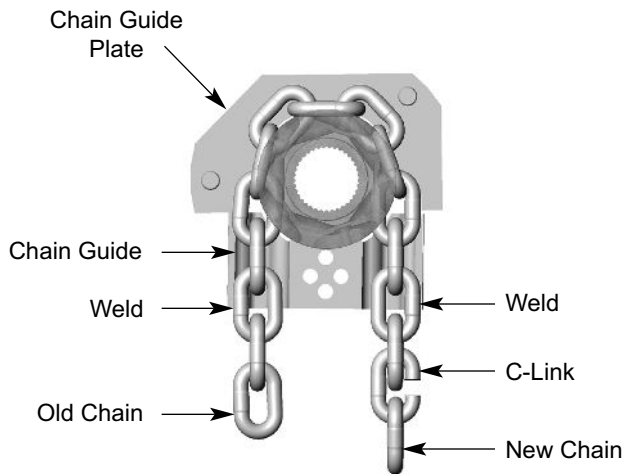

- d. Remove the load hook assembly from the old chain.
- e. Make a "C"-shaped chain link by grinding through one side of the ends of the link of either the old or new chain. See Figure 5-3.
- f. Hook the special "C" link to the end link of both chains thus joining them. BE SURE the weld of the upstanding links of the new chain are out away from the load sheave, and that proper orientation is observed for attachment of the slack end in paragraph "j" below.

#### NOTE

**On triple chain hoists be sure all welds are aligned like the welds on the old chain. It may be necessary to cut a link from one or both ends of the chain to accomplish this.**

- g. With the end cover off, connect the hoist to power supply. Be sure the green ground wire is properly grounded.
- h. Carefully jog the "UP" button and run the joined pieces of the chain into the hoist until about 12 inches of the new chain comes out the other side.
- i. DISCONNECT POWER from the hoist.
- j. Remove both the "C" link and the old chain from the slack end pin (No. 28, Figure 8-11). This can be accomplished by depressing the pin against the slack end spring (29) with a small screwdriver. Remove the soft split link (23) from the old chain and attach the link to the new chain. Depress the slack end pin and install the split link observing proper orientation of the slack end of the chain when secured. Avoid twists in the chain.
- k. Adjust the lower limit switch per paragraph 5-2b.
- l. Attach the bottom hook on single-chained hoists to the loose end of the chain. On double-chained hoists, feed the loose end of the chain through the load block (welds of the upstanding links will be in toward the sheave) and fasten the end of the chain to the dead end lug (No. 18, Figure 8-11).

#### NOTE

**On triple chain hoists, feed the loose end of the chain through the load block (welds away from sheave), around the idler sheave in the hoist, and to the center of the load block.**

- m. Adjust the upper limit switch per paragraph 5-2a.
- n. Lubricate the new chain per paragraph 5-6a and perform an operation test of the hoist.

#### 5-6. Lubrication

Proper lubrication is necessary for long, trouble-free hoist operation. Refer to the following and to Table 5-1, Recommended Lubrication Schedule, for lubrication points, type of lubricant and frequency of lubrication.

- a. Load Chain - Clean the load chain with a non-acid and non-caustic solvent and coat with SAE 90 gear oil. Wipe excess oil to prevent dripping. If the hoist is used in an atmosphere containing abrasive dust, the chain should be cleaned and oiled more frequently. Never apply grease to the chain.
- b. Gearing - The gear case of the hoist is filled at assembly with 46 oz. of a gear oil containing special friction reducing additives.

#### WARNING

**The use of gear oils other than that recommended in Table 5-1 can cause brake chatter or can render the load brake incapable of holding a load. A 48 oz. container of this oil is available from the Coffing® Hoists Co. (Part No. 14J1).**

- c. To check the oil level, remove the  $\frac{1}{8}$ " pipe plug from the side of the hoist. With the hoist hanging level, transmission oil should be even with the edge of the tapped plug hole.
- d. The length of time between necessary oil changes will depend on the severity of use the hoist receives. In general, the oil should be changed every 12 months of normal operation, or every 200 hours of actual hoist on-time. Very heavy use or operation in high ambient temperatures (over 105° F) will require that oil be changed more often. An indication of the need for oil replacement is load brake noise. If an erratic tapping sound is made when lowering a load, the oil should be changed.
- e. **Limit Switch Shaft.** To prevent rust, the threaded limit switch shaft should be given a light coat of grease or be sprayed with a general purpose lubricant.
- f. **Idler Sheave Bearing (double and triple chain models only).** Use a grease gun to put about a teaspoon of grease through the grease fitting in the bottom block shaft. Avoid pumping an excessive amount of grease into the bottom block. On triple chain hoists, use a grease gun to lubricate the idler sheave in the hoist until fresh grease pumps from the end of the sheave bearing.
- g. **Hook Bearing.** Apply a few drops of SAE 30 oil around the edge of the bearing.

## Figure 5-4. Chaining & Suspension Diagrams

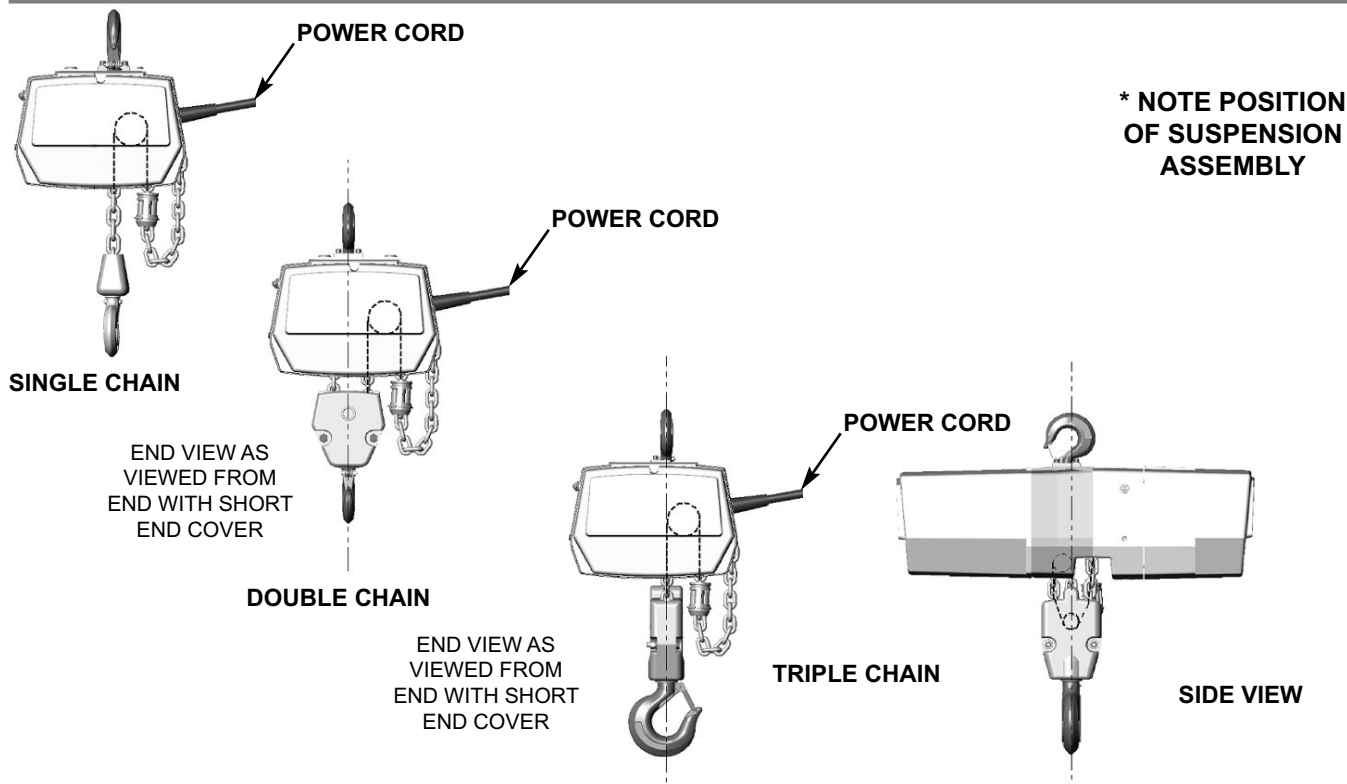

**TABLE 5-1. RECOMMENDED LUBRICATION SCHEDULE\* MODEL EC ELECTRIC CHAIN HOIST**

Figure and Index No.	Component	Type of Lubricant	Type of Service and Frequency of Lubrication		
			Heavy	Normal	Infrequent
Figure 8-6, No. 7	Load Chain	SAE 90 Gear Oil	Daily	Weekly	Monthly
Figure 8-5	Gearing	Coffing No. H7813 transmission oil (Kit No. 14J1 contains quantity of oil sufficient for one oil change)	At periodic inspection (See Figure 4-1, paragraph 5-6-2)		
Figure 8-8A, No. 9 Figure 8-8B, No. 7	Limit Switch Shaft	"WD-40" or general purpose spray lubricant	Monthly	Yearly	Yearly
Figure 8-6, No. _ and No. _	Load Hook Bearing	SAE 30 Gear or Motor Oil	Weekly	Monthly	Yearly
Figure 8-1, No. 1, 3, 4 & 5	Top Hook or Suspension Lug Bearing Surfaces	SAE 30 Gear or Motor Oil	Monthly	Yearly	Yearly
Figure 8-10C, No. 11 Figure 8-10D, No. 11	Idler Sheave Bearing (Bushing)	NLGI #2 multi-purpose lithium base grease (Coffing No. H7610)	At periodic inspection (See Figure 4-1)		

NOTE: All bearings except hook and idler sheave bearings are pre-lubricated and sealed.  
\*This lubrication schedule is based on a hoist operating in normal environmental conditions. Hoists operating in adverse atmospheres containing excessive heat, corrosive fumes or vapors, abrasive dust, etc., should be lubricated more frequently.

## Troubleshooting

### 6-1. General

Use the following table as an aid to troubleshoot your hoist. If you do not have an experienced machinist or electrician to do your repair work, we recommend that you send your hoist to an approved service center for repairs.

Trouble	Possible Cause	Remedy
Hook fails to stop at end of travel	Limit switches not operating	Check adjustment (see paragraph 5-2). Check connections against wiring diagram. Tighten loose connections or replace.
	Limit switch nuts not moving on shaft	Check for stripped threads or bent nut guide.
	Magnetic reversing switch malfunction	Remove electrical cover and check reversing switch.
Hoist does not respond to pushbutton	Power failure in supply lines	Check circuit breakers, switches and connections in power supply lines.
	Wrong voltage or frequency	Check voltage and frequency of power supply against the rating on the nameplate of the hoist.
	Improper connections in hoist or pushbutton station	Check all connections at line connectors and on terminal block. Check terminal block on dual-voltage hoists for proper voltage connections.
	Motor brake does not release	Check connections to the solenoid coil. Check for open or short circuit. Check for proper adjustment (see paragraph 5-3)
	Faulty magnetic hoist control switch	Check coils for open or short circuit. Check all connections in control circuit. Check for burned contacts. Replace as needed.
Hook does not stop promptly	Hoist overloaded	Reduce load to within rated capacity of hoist
	Brake not holding	Check motor brake adjustment (see paragraph 5-3) and load brake (Figure 4-3)
Hook moves in wrong direction	Three-phase reversal	Reverse any two wires (except the green ground wire) at the power source
	Improper connections	Check all connections against wiring diagram
Hoist hesitates to lift when energized	Hoist overloaded	Reduce load within rated capacity of hoist
	Motor brake requires adjustment	Check motor brake adjustment (Figure 5-3)
	Worn overload limiting clutch	Replace clutch
	Low voltage	Check voltage at hoist power cord with hoist starting. Voltage should be no less than 90% of voltage specified on hoist
	Faulty SINPAC starting switch or start capacitor (single-phase hoists only)	Replace faulty component
Hook raises but will not lower (When motor is running)	Consult Factory or Authorized Coffing Hoist Warranty Repair Station	

## Troubleshooting cont'd

Trouble	Possible Cause	Remedy
Hook raises but will not lower (When motor is not running)	"Down" circuit open	Check circuit for loose connections. Check "Down" limit switch for malfunction
	Broken Conductor in pushbutton cable	Check each conductor in the cable. If one is broken, replace entire cable.
	Faulty magnetic hoist control switch	Check coils for open or short circuit. Check all connections in control circuit. Check for burned contacts. Replace as needed
Hook lowers but will not raise	Hoist overload	Reduce load to within rated capacity
	Low voltage	Determine cause of low voltage and bring up to at least 10% of the voltage specified on hoist. Line voltage should be measured while holding or lifting load.
	"UP" circuit open	Check circuit for loose connections. Check "UP" limit switch for malfunction
	Broken conductor in pushbutton cable	Check each conductor in the cable. If one is broken, replace entire cable
	Faulty magnetic hoist control switch	Check coils for open or short circuit. Check all connections in control circuit. Check for burned contacts. Replace as needed.
	Faulty capacitor (single-phase hoists only)	Check starting capacitor in motor. Replace if necessary.
	Worn overload limiting clutch	Replace clutch.
Lack of proper lifting speed	Hoist overloaded	Reduce load to within rated capacity
	Motor brake is dragging	Check for proper brake adjustment or other defects. (see paragraph 5-3)
	Low voltage	Bring up voltage to plus or minus 10% of voltage specified on hoist. Line voltage should be measured while hoist is lifting load.
	Overload limiting clutch slipping	Replace clutch.
Load brake "noise" (erratic tapping sounds or squeals)	Need transmission oil change or improper lubricant has been used	Change transmission oil. (Table 5-1) Note: Hoist Warranty is void if unapproved oil is used
	Load brake malfunctioning	Check load brake operation (Figure 4-3)
Motor brake "noise" or chatter (while starting hoist)	Brake needs adjustment	Adjust as per paragraph 5-3
	Low voltage	Check voltage at hoist power cord with hoist starting. Voltage should be no less than 90% of the voltage specified. 115 volt hoists are particularly subject to voltage drop problems due to their high current draw. Conversion to 230 volt operation is suggested in extreme cases
Motor brake "buzz" (anytime hoist is running)	Brake needs adjustment	Adjust as per paragraph 5-3
	Broken shading coil on brake frame	Replace shading coil or complete brake frame assembly

# Wiring

## Safety Notes

**Disconnect power from hoist before removing end covers.**

### 7-1. Wiring Diagrams

The wiring diagrams for standard hoist models are reproduced on the following pages. In addition, every hoist should have a wiring diagram located inside the long end cover.

### 7-2. Voltage Conversion

Standard single phase units are convertible from 115 to 230 volts, and standard single speed three phase units are convertible from 230 to 460 volts. Conversion to the alternate voltage can be accomplished with the following procedure.

- a. Be sure power is disconnected from hoist. Remove long end cover.
- b. SINGLE PHASE HOISTS (with SINPAC® switch): Transfer leads per the appropriate terminal block schematic.
- c. THREE PHASE HOISTS: Transfer leads per the appropriate terminal block schematic.

### CAUTION

**Do not move any wires or make any changes to the wiring except at the terminal block.**

- d. After converting voltage, check for proper phasing of three phase units and check for proper limit switch operation.

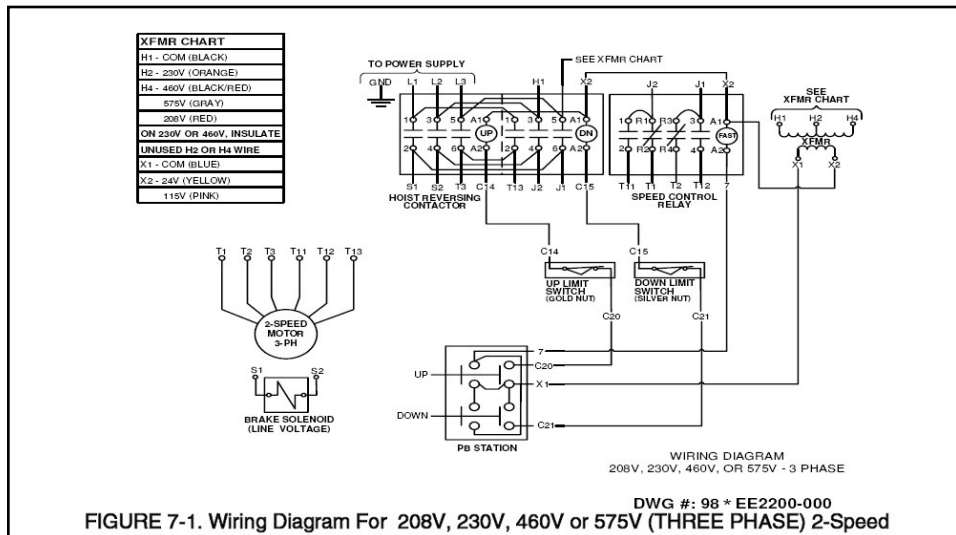
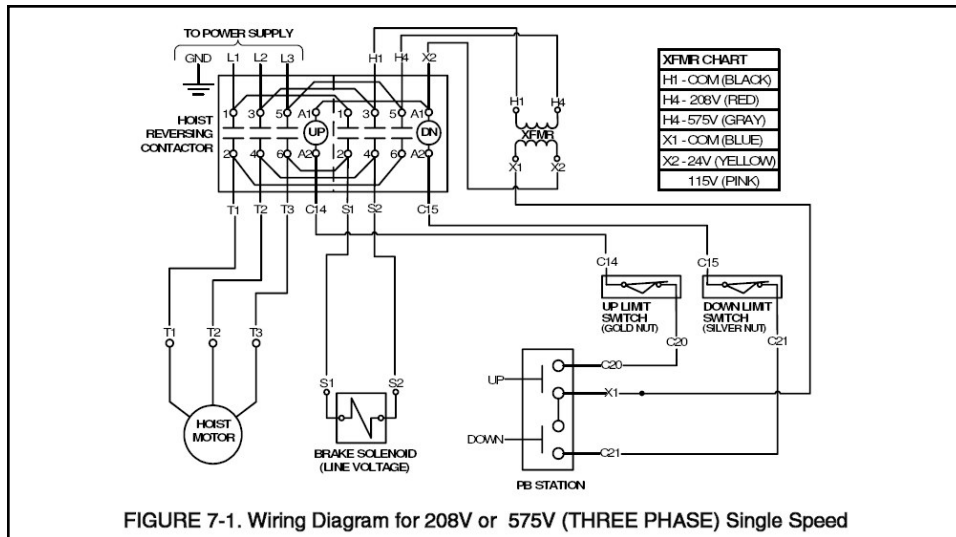

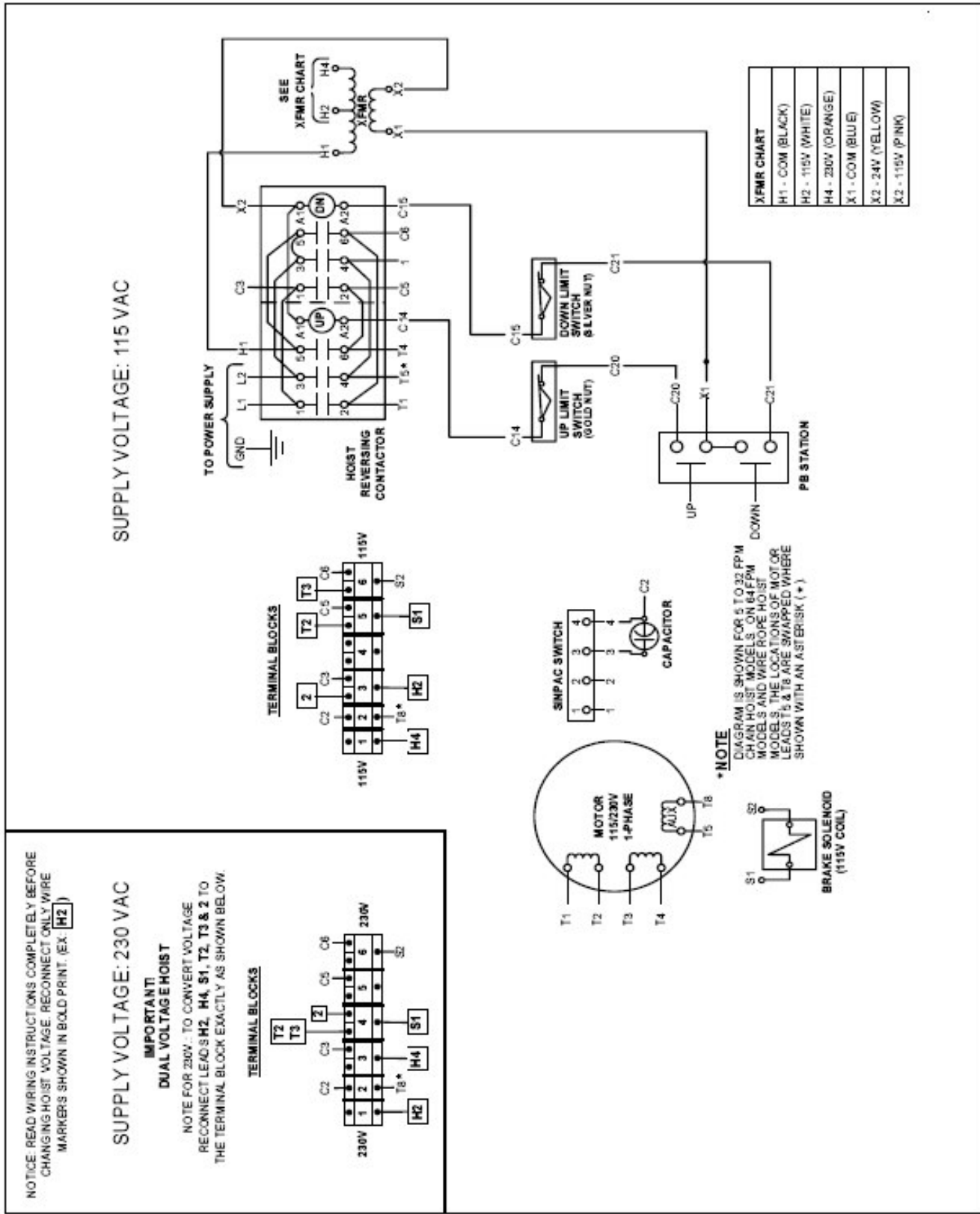

**FIGURE 7-2. WIRING DIAGRAM NO. 981EE2100-000 (115/230V, SINGLE PHASE)**



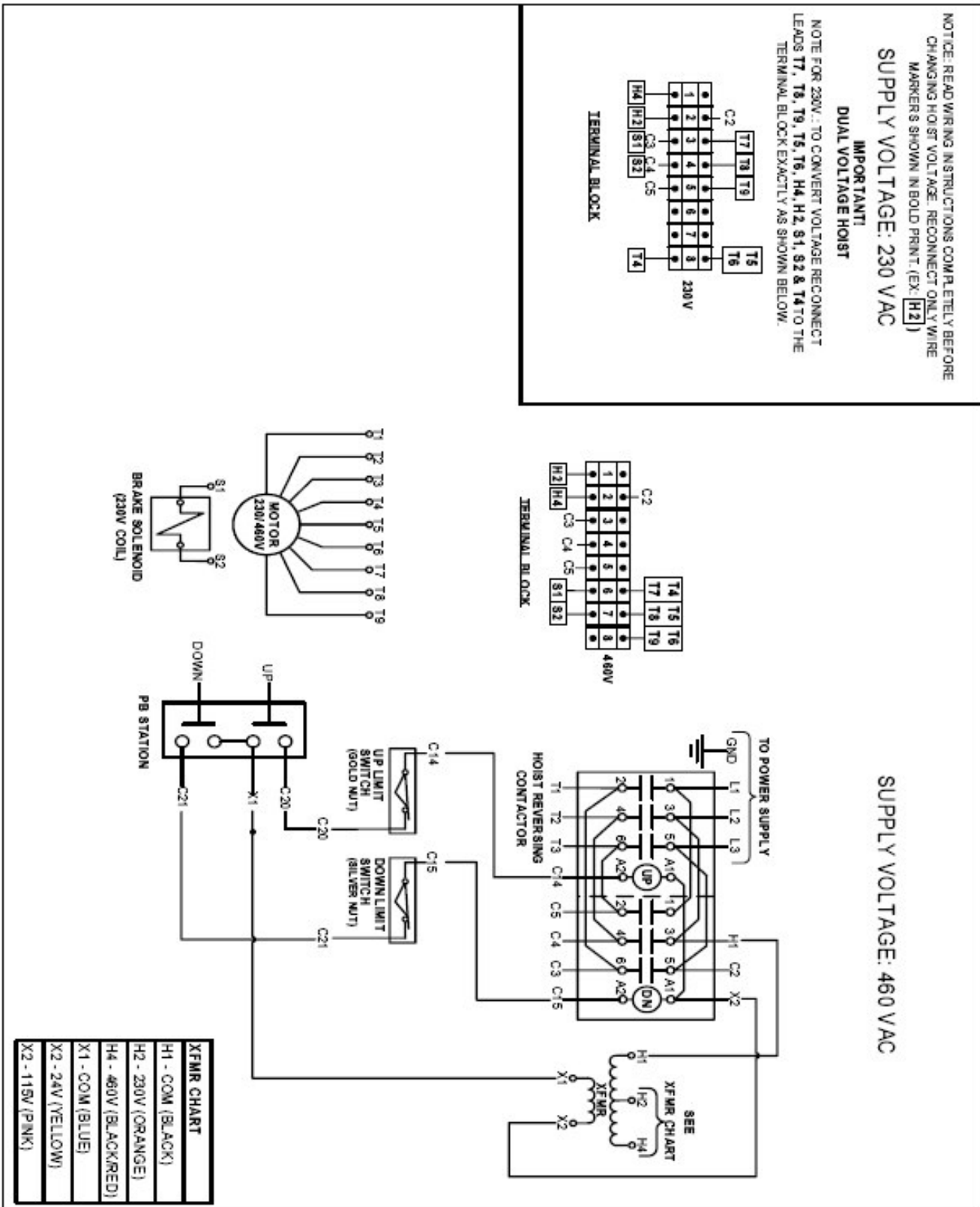

FIGURE 7-2. WIRING DIAGRAM NO. 983EE2100-000(230V/ 460V, SINGLE SPEED)

## Illustrated Parts List

### 8-1. General

The following exploded drawings provide a complete list of parts used in the standard EC hoist models (shown in Table 1-1, page 3). Since several different models of hoists are covered by the manual, differences may be noted between the appearance of your hoist part and the reference illustration. If this is the case, the parts list will show several different part numbers with sufficient information to allow the selection of the correct part number.

### 8-2. How to Use the Parts List

a. The parts list consists of four columns as follows:

- 1.) Index Number
- 2.) Usage Code - This column may contain a code relating to the model numbers of, or other data relating to the hoist in which the part is used. Usage codes are as follows:

- A- Single Phase Hoists (Single Speed)
- B- Three Phase Hoists (Single Speed)
- C- Three Phase Hoists (Two Speed)
- D- Hoist with 1/4" load chain (Models: EC-0516, EC-0532, EC-0564, EC-1009, EC-1016, EC-1032, EC-2004 and EC-2008).
- E- Hoist with 9/32" load chain (Models: EC-2012, EC-2016, EC-4006, EC-4008 and EC-6005).
- F- Single Chain Hoists (Models: EC-0516, EC-0532, EC-0564, EC-1009, EC-1016 and EC-1032)
- G- Double Chain Hoists (Models: EC-2004, EC-2008, EC-4006 and EC-4008)
- H- Single Chain Hoists (Models: EC-2012 and EC-2016)
- J- Triple Chain Hoists (Model: EC-6005)

- 3.) Part Number
- 4.) In addition to basic part name, this column contains descriptions which are essential for choosing the correct part number when more than one is listed.

b. How to determine proper part number:

- 1.) Locate the index number in the corresponding figure of the parts list.
- 2.) If only one part number is listed for the index number, that part number should be ordered.
- 3.) If more than one usage code and part number is listed for that index number, choose the correct usage code by comparing the model number or electrical characteristics of your hoist with the usage codes above.

4.) If more than one part number is listed with the same usage code, the information under "Part Name" will determine the correct part number. This is also the case if no usage code is listed and more than one part number is listed for the index number.

INDEX NO.	USAGE CODE	PART NO.	PART NAME
5	B	821JL432	<b>Transformer</b> (Primary 230/460V, Sec. 24V)
	B	821JL431	<b>Transformer</b> (Primary 230/460V, Sec. 115V)

### 8-3. How to Order Replacement Parts

When ordering parts or requesting information concerning your EC hoist, always include the hoist model number and serial number. The Serial Number Label is located on rear of hoist near power cord entry hole. See index No. 6, Figure 8-2 and illustration below.

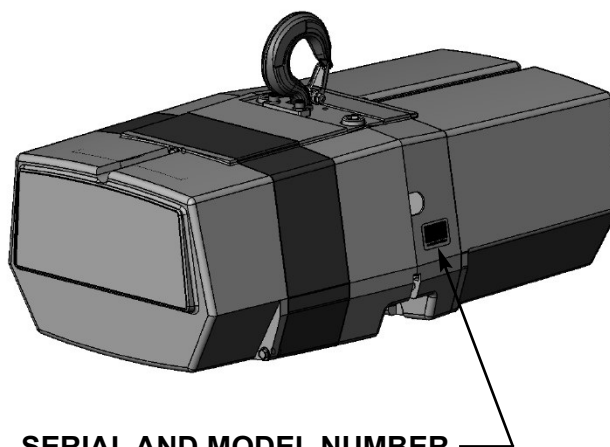

**SERIAL AND MODEL NUMBER**

### EXAMPLE A

INDEX NO.	USAGE CODE	PART NO.	PART NAME
6	E	35J1	Transmission Housing
	D	35J2	Transmission Housing

Repair parts are available only from Coffing distributors or authorized repair facilities. It is recommended that repair part orders be directed to the authorized repair facility nearest you.

**To find a local Coffing Hoist repair/warranty center please visit our website at [www.coffinghoists.com](http://www.coffinghoists.com)**

Contact your nearest Coffing Service Center for parts and service. Refer to pages 41 and 42 for a complete list. Please have the hoist model number, serial number, and part number with description available for reference.

## Figure 8-1. Suspension Assemblies

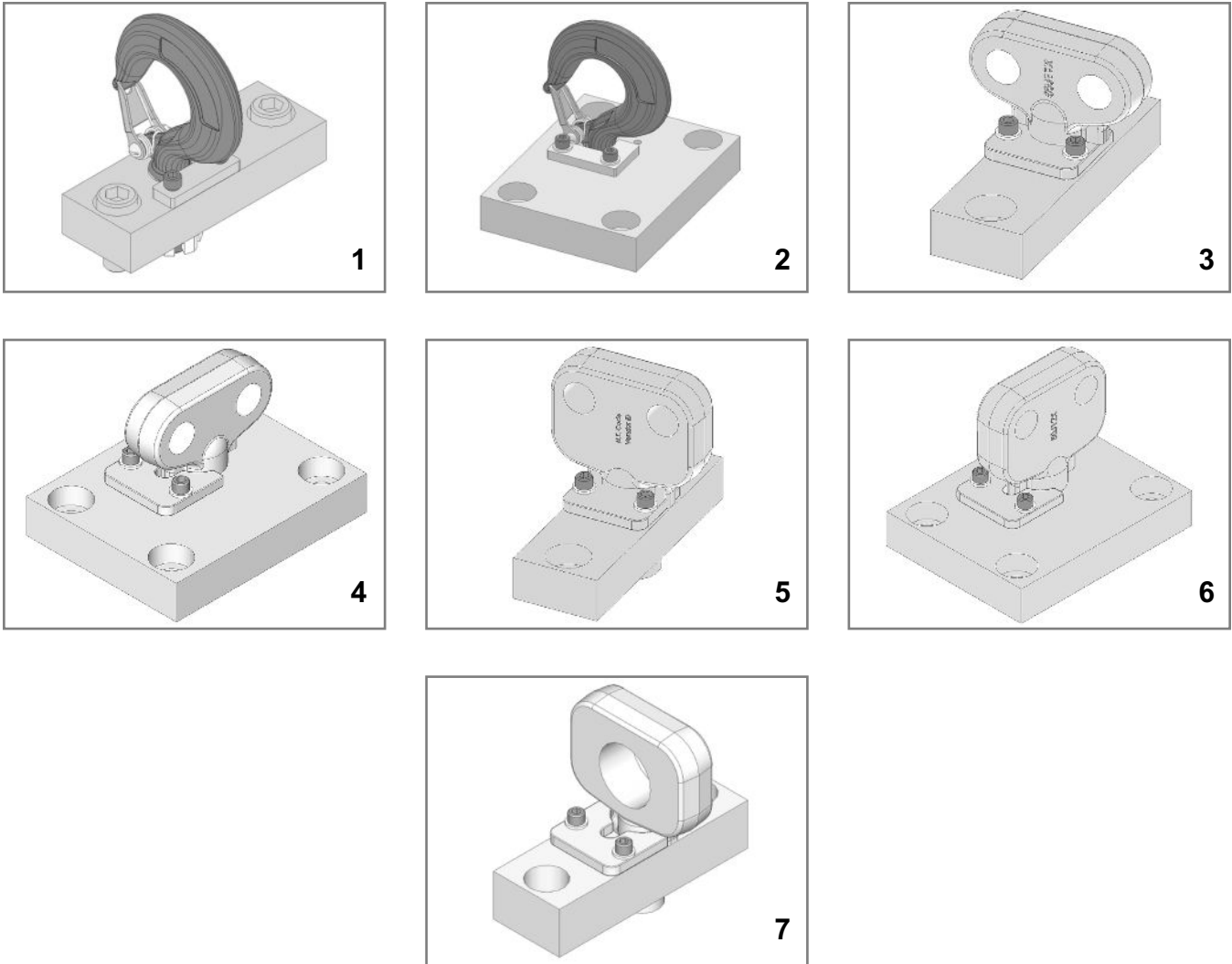

### Parts List for Suspension Assemblies

Index No.	Usage Code	Part No.	Part Name
1	F, G, H	14J25 14J26	Hook Assembly Kit - Swivel Hook Assembly Kit - Rigid
2	J	3JG23	Hook Assembly Kit - Rigid (3 ton only)
3	F, G, H	14J3	Trolley Lug Assembly Kit - Plain, Geared & Parallel Mounted Motorized Trolley
4	J	50JG53	Trolley Lug Assembly Kit - Plain or Geared Trolley Only (3 ton only)
5	F, G, H	14J4	Trolley Lug Assembly Kit - Cross Mounted Motorized Trolley
6	J	50JG54	Trolley Lug Assembly Kit - Motorized Trolley Only (3 ton only)
7	F, G, H	50JG22	Multi-Purpose Lug Assembly Kit

## Figure 8-2. Basic Hoist

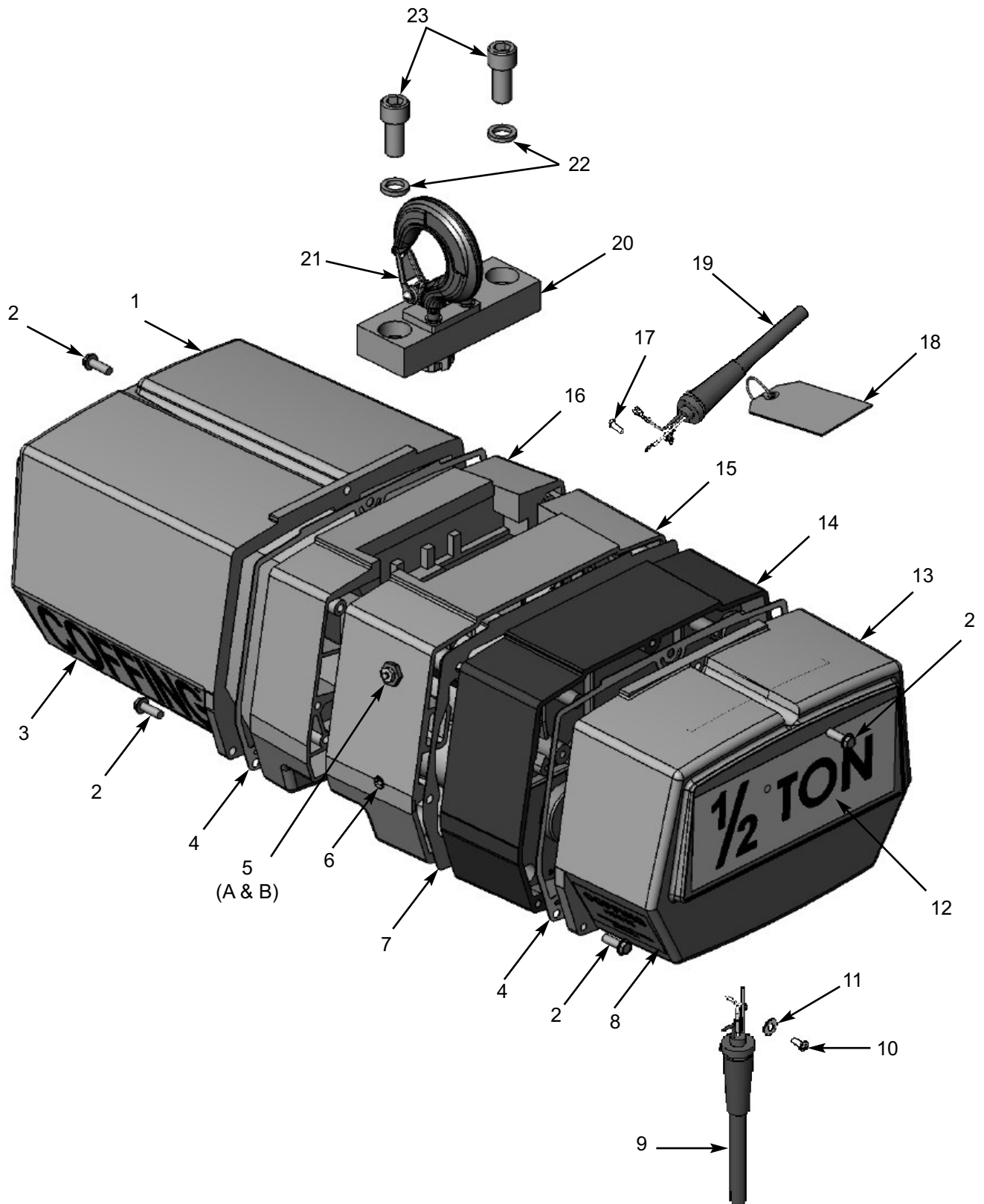

Contact your nearest Coffing Service Center for parts and service. Refer to pages 41 and 42 for a complete list. Please have the hoist model number, serial number, and part number with description available for reference.

Index No.	Usage Code	Part No.	Part Description
1		36J2	Electrical Cover
2		H-2923P	Screw (slotted hex head)
3		677J2	Decal, Coffing
4		560J4	Gasket (Brake & Electrical Covers)
5A		H-6293	Reducer Bushing
5B		SK1912-21W	Pressure Relief Plug
6		S25-13	Level Plug
7		560J5	Gasket (Transmission)
8		676J2B	Decal, Coffing Hoists Information
9		—	Pushbutton Cable (see Figure 8-10A & 8-10B)
10		H-2970	Screw
11		H-4002P	Flat Washer
12		675J1B	Decal, Capacity (¼ Ton)
		675J2B	Decal, Capacity (½ Ton)
		675J3B	Decal, Capacity (1 Ton)
		675J4B	Decal, Capacity (2 Ton)
		675J11	Decal, Capacity (3 Ton)
13		36J1	Brake Cover
14		34JG1	Transmission Cover (includes 2 oil seals)
15	E	35JG1	Transmission Housing
	D	35JG2	Transmission Housing
16		33J1	Sheave Housing (Models EC-2012, EC-2016, EC-4006 and EC-4008)
		33J2	Sheave Housing (Models EC-0564 & EC-1032)
		33J2-1	Sheave Housing (Models EC-0516, EC-0532, EC-1009, EC-1016, EC-2004 & EC-2008)
	J	33J19	Sheave Housing (Model EC-6005)
17		H-2981P	Screw
18		JF679-1	Tag (230V - 1 Phase)
		JF679-2	Tag (230V - 3 Phase)
		JF679-3	Tag (460V - 3 Phase)
		JF679-4	Tag (115V - 1 Phase)
19	A	951JL1	Power Cable (¼ & ½ Hp)
	A	952JL1	Power Cable (1 Hp)
	B	953JL1	Power Cable
20		—	Suspension Assembly (see Figure 8-1)
21	F, G, H	4X1305	Latch Kit
	J	4X1307	Latch Kit (3 Ton only)
22		H-4086P	Lock Washer (included in all Suspension Assembly Kits)
23		703J1	Screw (included in all Suspension Assembly Kits)
△	A	679J1	Decal, Power (115/230V)
	B	679J2	Decal, Power (230/460V)
	A, B, C	679J3	Decal, Power (230V)
	B, C	679J4	Decal, Power (460V)
	B, C	679J5	Decal, Power (575V)
	B, C	679J36	Decal, Power (208V)
△	A, B	940JE1	Wiring Harness
	C	940JE1-36	Wiring Harness

(△) Not Shown

## Figure 8-3A. Motor Parts (1-Speed)

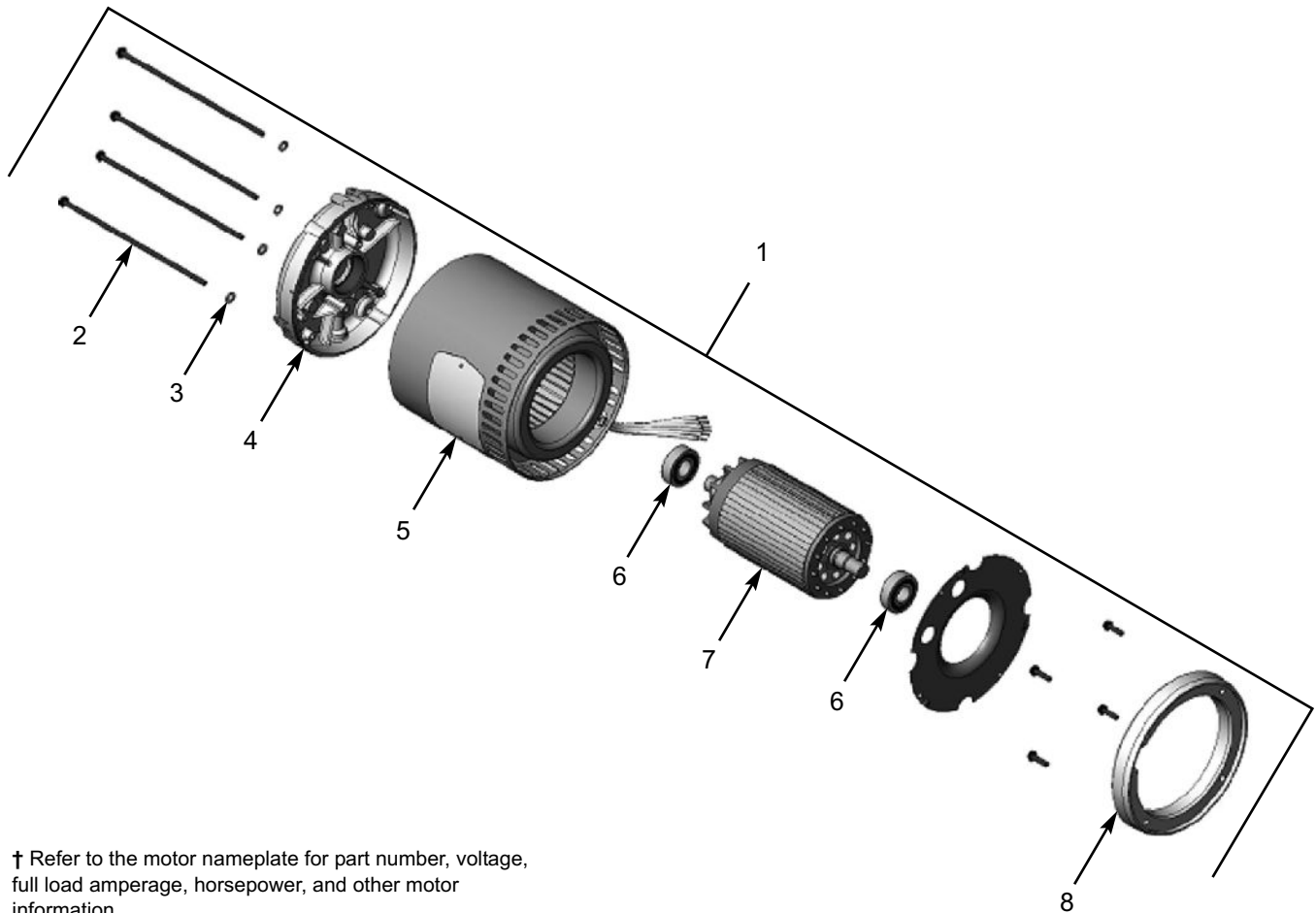

† Refer to the motor nameplate for part number, voltage, full load amperage, horsepower, and other motor information.

Ref. No.	Description	Part No.	Qty.	Ref. No.	Description	Part No.	Qty.
1	Hoist Motor (1-Speed)				¼ hp, 208V-3Ph-60Hz	863J247B	1
	¼ hp, 115/230V-1Ph	861J241B	1		½ hp, 208V-3Ph-60Hz	863J248B	1
	½ hp, 115/230V-1Ph	861J242B	1		1 hp, 208V-3Ph-60Hz	863J149B	1
	1 hp, 115/230V-1Ph	861J144B	1	2	Thru Bolt	*	
	¼ hp, 230/460V-3Ph-60Hz	863J241B	1	3	#10 Spring Lockwasher	*	
	½ hp, 230/460V-3Ph-60Hz	863J242B	1	4	End Shield	*	
	1 hp, 230/460V-3Ph-60Hz	863J144B	1	5	Stator Assembly	*	
	¼ hp, 575V-3Ph-60Hz	863J244B	1	6	Bearing	*	
	½ hp, 575V-3Ph-60Hz	863J245B	1	7	Rotor Assembly	*	
	1 hp, 575V-3Ph-60Hz	863J148B	1	8	Adapter Plate (1hp Only)	*	

\* Not available as an individual part.

Contact your nearest Coffing Service Center for parts and service. Refer to pages 41 and 42 for a complete list. Please have the hoist model number, serial number, and part number with description available for reference.

## Figure 8-3B. Motor Parts (2-Speed)

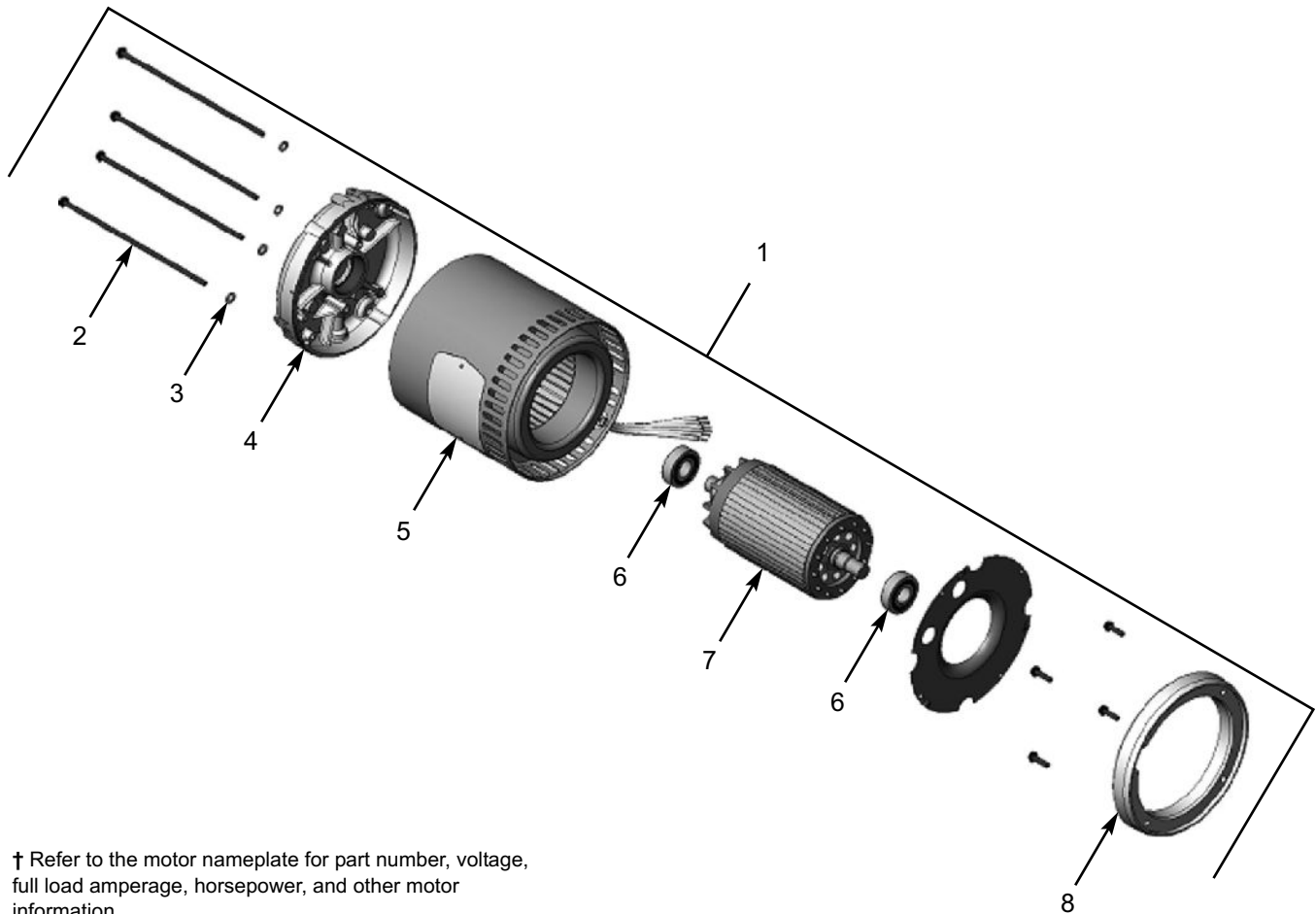

† Refer to the motor nameplate for part number, voltage, full load amperage, horsepower, and other motor information.

Ref. No.	Description	Part No.	Qty.	Ref. No.	Description	Part No.	Qty.
1	Hoist Motor (2-Speed)						
	¼ hp, 230V-3Ph-60Hz	873J241B	1		¼ hp, 208V-3Ph-60Hz	873J251B	1
	½ hp, 230V-3Ph-60Hz	873J242B	1		½ hp, 208V-3Ph-60Hz	873J249B	1
	1 hp, 230V-3Ph-60Hz	873J144B	1		1 hp, 208V-3Ph-60Hz	873J145B	1
	¼ hp, 460V-3Ph-60Hz	873J244B	1	2	Thru Bolt	*	
	½ hp, 460V-3Ph-60Hz	873J245B	1	3	#10 Spring Lockwasher	*	
	1 hp, 460V-3Ph-60Hz	873J148B	1	4	End Shield	*	
	¼ hp, 575V-3Ph-60Hz	873J247B	1	5	Stator Assembly	*	
	½ hp, 575V-3Ph-60Hz	873J245B	1	6	Bearing	*	
	1 hp, 575V-3Ph-60Hz	873J248B	1	7	Rotor Assembly	*	
				8	Adapter Plate (1hp Only)	*	

\* Not available as an individual part.

## Figure 8-4A. Controller Area (Single Phase)

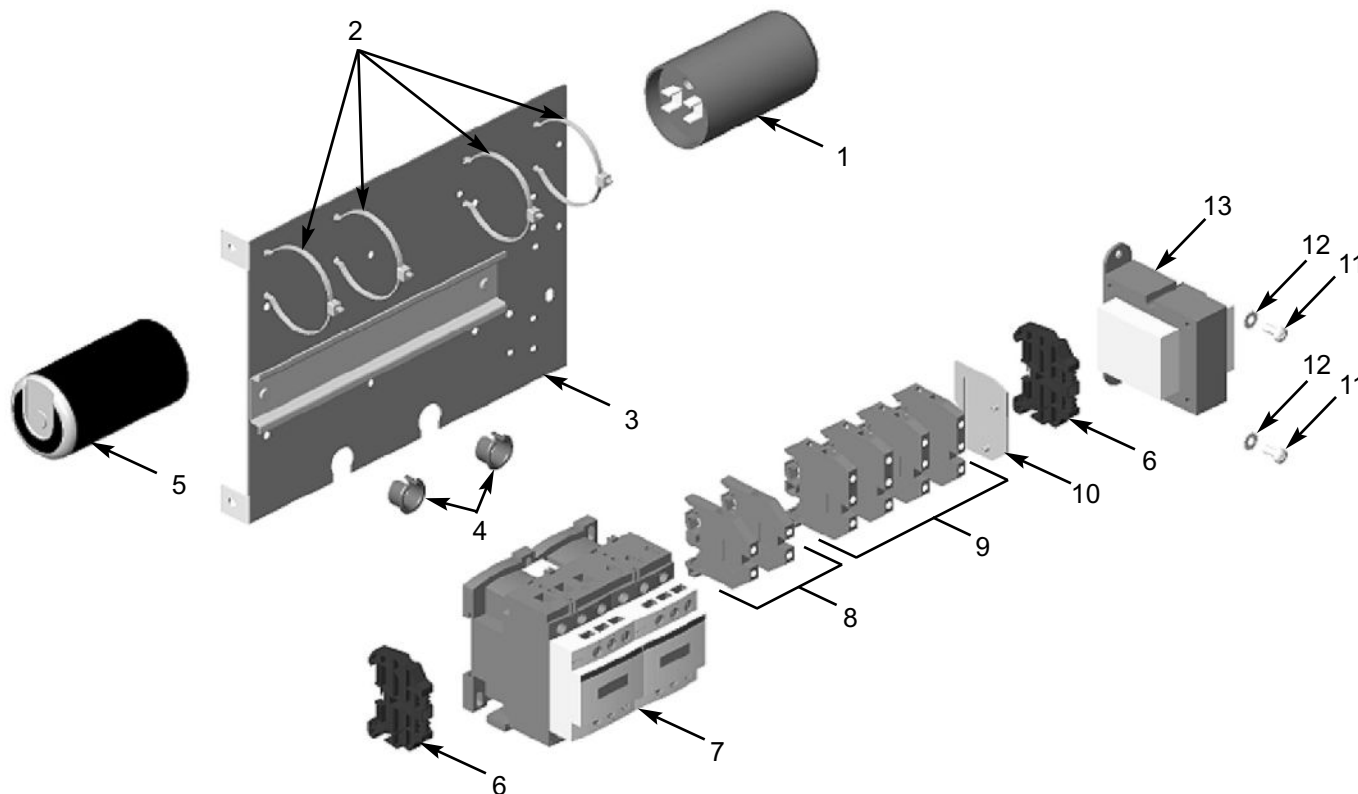

Ref. No.	Description	Part No.	Qty.	Ref. No.	Description	Part No.	Qty.
1	Capacitor			8	Terminal Block	909J10	2
	¼ & ½ hp	JL810-3	1	9	Terminal Block	909J14	4
	1 hp	JL810-4	1	10	End Plate	909J15	1
2	Cable Tie	H-9006	4	11	8-32 UNC x 5/16" Screw	H-2751	2
3	Panel Plate	257JG200	1	12	#8 External-tooth Lockwasher	H-4158	2
4	Grommet	H-7956	2	13	Transformer*		
5	Starting Switch	839J3	1		Sec.: 24V	821J412	1
6	End Clamp	909J13	2		Sec.: 115V	821J411	1
7	Reversing Contactor*			△	15 ft Power Cord Assembly		
	¼ & ½ hp:				¼ & ½ hp, 115/230V	951JL1	1
	24V	28860	1		1 hp, 115/230V	952JL1	1
	115V	24799	1				
	1 hp:						
	24V	24791	1				
	115V	28905	1				

\* Coil voltage of the contactor and the secondary voltage of the transformer are the same. This is referred to as the control voltage. Standard units are supplied with 24V control. (△) Not Shown



Contact your nearest Coffing Service Center for parts and service. Refer to pages 41 and 42 for a complete list. Please have the hoist model number, serial number, and part number with description available for reference.

## Figure 8-4B. Controller Area (Three Phase)

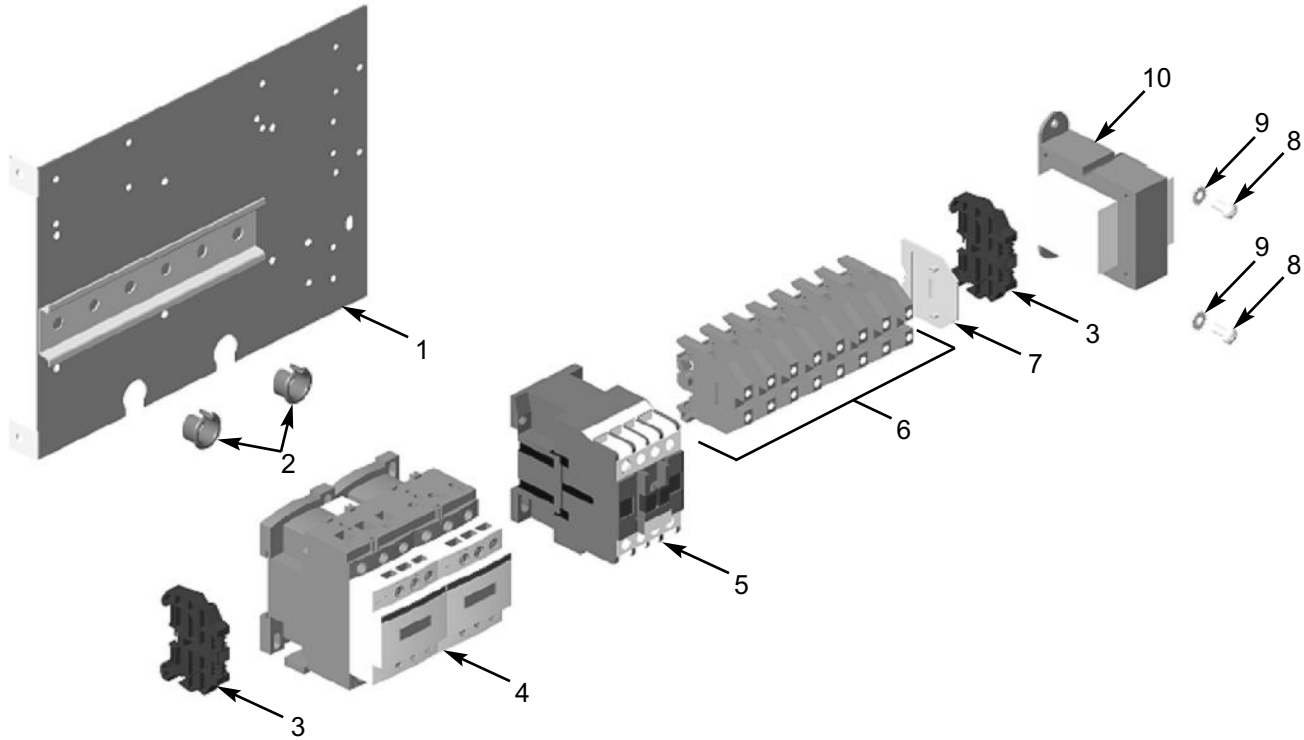

Ref. No.	Description	Part No.	Qty.	Ref. No.	Description	Part No.	Qty.
1	Panel Plate	257JG200	1	6	Terminal Block		
2	Grommet	H-7956	2		230/460V, 1-Speed Models	909J10	8
3	End Clamp	909J13	2	7	End Plate		
4	Reversing Contactor*				230/460V, 1-Speed Models	909J12	1
	¼ & ½ hp:			8	8-32 UNC x 5/16" Screw	H-2751	2
	24V	28860	1	9	#8 External-tooth Lockwasher	H-4158	2
	115V	24799	1	10	Transformer*		
	1 hp:				Pri.: 230/460V, Sec.: 24V	821J432	1
	24V	25943	1		Pri.: 230/460V, Sec.: 115V	821J431	1
	115V	24729	1		Pri.: 575V, Sec.: 24V	821J452	1
5	Speed Control Relay (2-speed only)*				Pri.: 575V, Sec.: 115V	821J451	1
	¼ & ½ hp, 24V Coil	28878	1		Pri.: 208V, Sec.: 24V	821J472	1
	¼ & ½ hp, 115V Coil	28870	1		Pri.: 208V, Sec.: 115V	821J471	1
	1 hp, 24V Coil	28885	1				
	1 hp, 115V Coil	28879	1				

\* Coil voltage of the contactor and the secondary voltage of the transformer are the same. This is referred to as the control voltage. Standard units are supplied with 24V control.

## Figure 8-5. Transmission

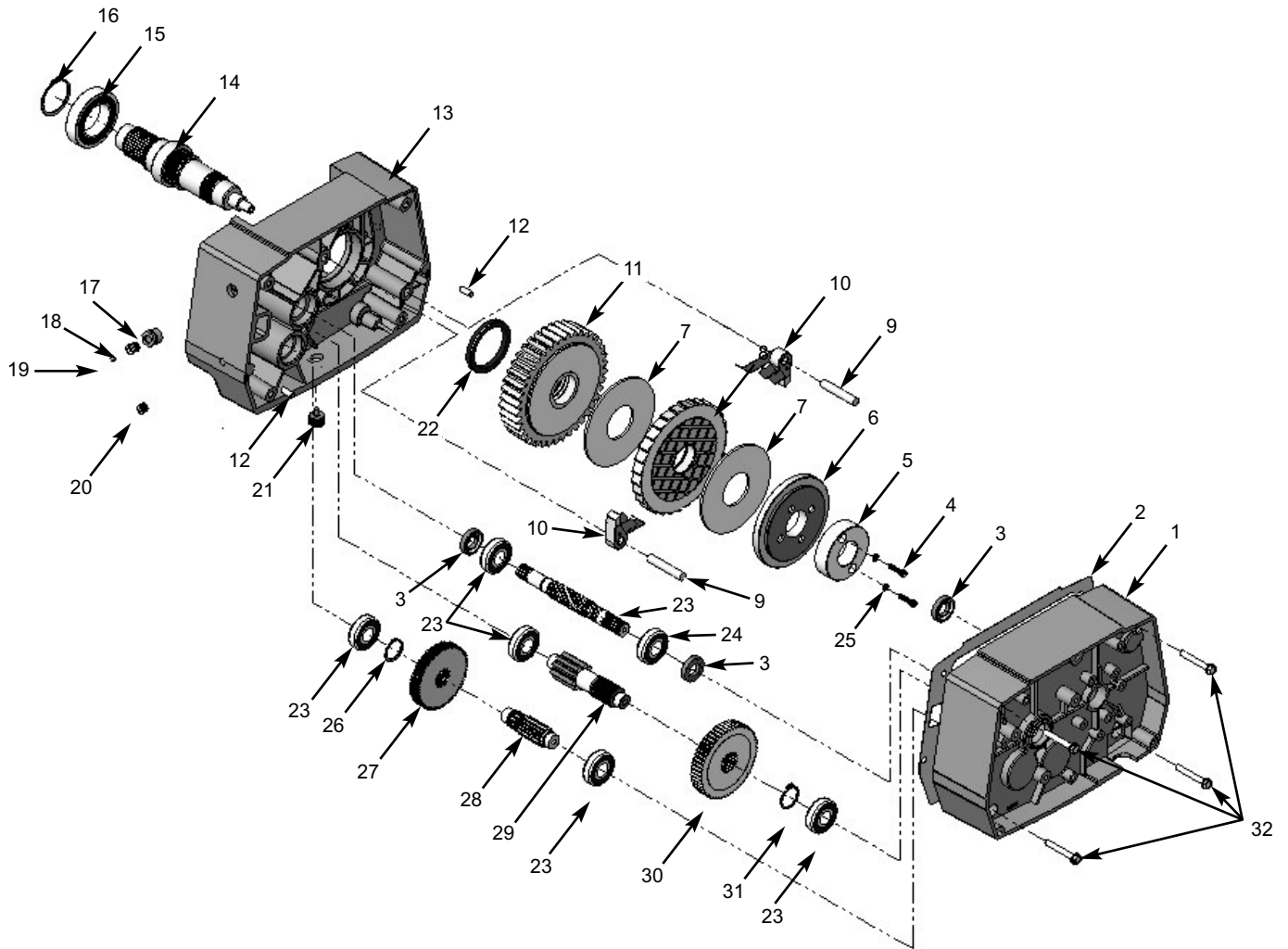

Contact your nearest Coffing Service Center for parts and service. Refer to pages 41 and 42 for a complete list. Please have the hoist model number, serial number, and part number with description available for reference.

Ref. No.	Usage Code	Part Description	Part No.	Qty.
1		Transmission Cover Assembly (includes Ref. No. 3)	34JG1	1
2		Gasket	560J5	1
3		Seal	561K2	3
4		Screw, Hex Socket #10-32 x 3/4"	H-2255	2
5		Load Brake Nut	130J3	1
6		Pressure Plate	5J6	2
7		Brake Disc (all models except EC-0564)	580J8	2
8		Ratchet (all models except EC-0564)	7JG15-1	1
		Spacer (model EC-0564 only)	7J14	1
9		Pawl Assembly	25JG4-1	2
10		Dowel Pin, Ratchet Ring	H-5493	2
11		Output Gear Assembly	407JG25	1
12		Dowel Pin	H-5382	2
13	E	Transmission Housing (Usage Code "E")	35JG1	1
	D	Transmission Housing (Usage Code "D")	35JG2	1
14	E	Sheave Shaft Assembly (Usage Code "E")	132JG21	1
	D	Sheave Shaft Assembly (Usage Code "D")	132JG22	1
15		Bearing	500K29	1
16		Retaining Ring	H-5539	1
17		Reducer Bushing	H-6293	1
18		Pressure Relief Plug	SK1912-21W	1
19		O-Ring	H-5606	1
20		Level Plug	S25-13	1
21		Drain Plug	H-6268	1
22		Seal	MA-562	1
		Input Pinion (Models EC-2012, EC-2016, EC-4006, EC-4008 & EC-6005)	400J1	1
		Input Pinion (Models EC-0516, EC-1016 & EC-2008)	400J2	1
		Input Pinion (Models EC-0532 & EC-1032)	400J3	1
		Input Pinion (Models EC-0564)	400J4	1
23		Input Pinion (Models EC-1009 & EC-2004)	400J9	1
24		Bearing	500K7	6
25		Lock Washer	H-4133	2
		Retaining Ring (Models EC-0516, EC-1016, EC-2008, EC-2016, EC-4008 & EC-6005)	H-5549	1
		Retaining Ring (Models EC-1009, EC-2004, EC-2012 & EC-4006)	H-5553	1
26		Retaining Ring (Models EC-0532 & EC-1032)	H-5530	1
		Input Gear (Models EC-2012 & EC-4006)	401J1	1
		Input Gear (Models EC-0516, EC-1016 & EC-2008)	401J2	1
		Input Gear (Models EC-0532 & EC-1032)	401J3	1
		Input Gear (Models EC-2016, EC-4008 & EC-6005)	401J5	1
27		Input Gear (Models EC-1009 & EC-2004)	401J9	1
28		Intermediate Pinion (Models EC-1009, EC-2004, EC-2012 & EC-4006)	402J1	1
		Intermediate Pinion (Models EC-0516, EC-1016, EC-2008, EC-2016, EC-4008 & EC-6005)	402J2	1
		Intermediate Pinion (Models EC-0532 & EC-1032)	402J3	1
29		Output Pinion	404J1	1
		Slip Clutch Assembly (Models EC-0516)	591JG1	1
		Slip Clutch Assembly (Models EC-0532)	591JG2	1
		Slip Clutch Assembly (Models EC-0564)	591JG3	1
		Slip Clutch Assembly (Models EC-1016)	591JG4	1
		Slip Clutch Assembly (Models EC-1032)	591JG5	1
		Slip Clutch Assembly (Models EC-2012 & EC-4006)	591JG6	1
		Slip Clutch Assembly (Models EC-2016, EC-4008 & EC-6005)	591JG7	1
30		Slip Clutch Assembly (Models EC-1009 & EC-2004)	591JG20	1
31		Retaining Ring	H-5503	1
32		Screw, 1/4-20 x 1-3/4"	H-2978P	4
△		Transmission Oil	14J1	-
△		Seal Kit (includes: (3) 561K2 Seals, (1) MA-562 Seal & (1) 560J5 Gasket)	14J2	-

(△) Not Shown

## Figure 8-6. Chaining Parts

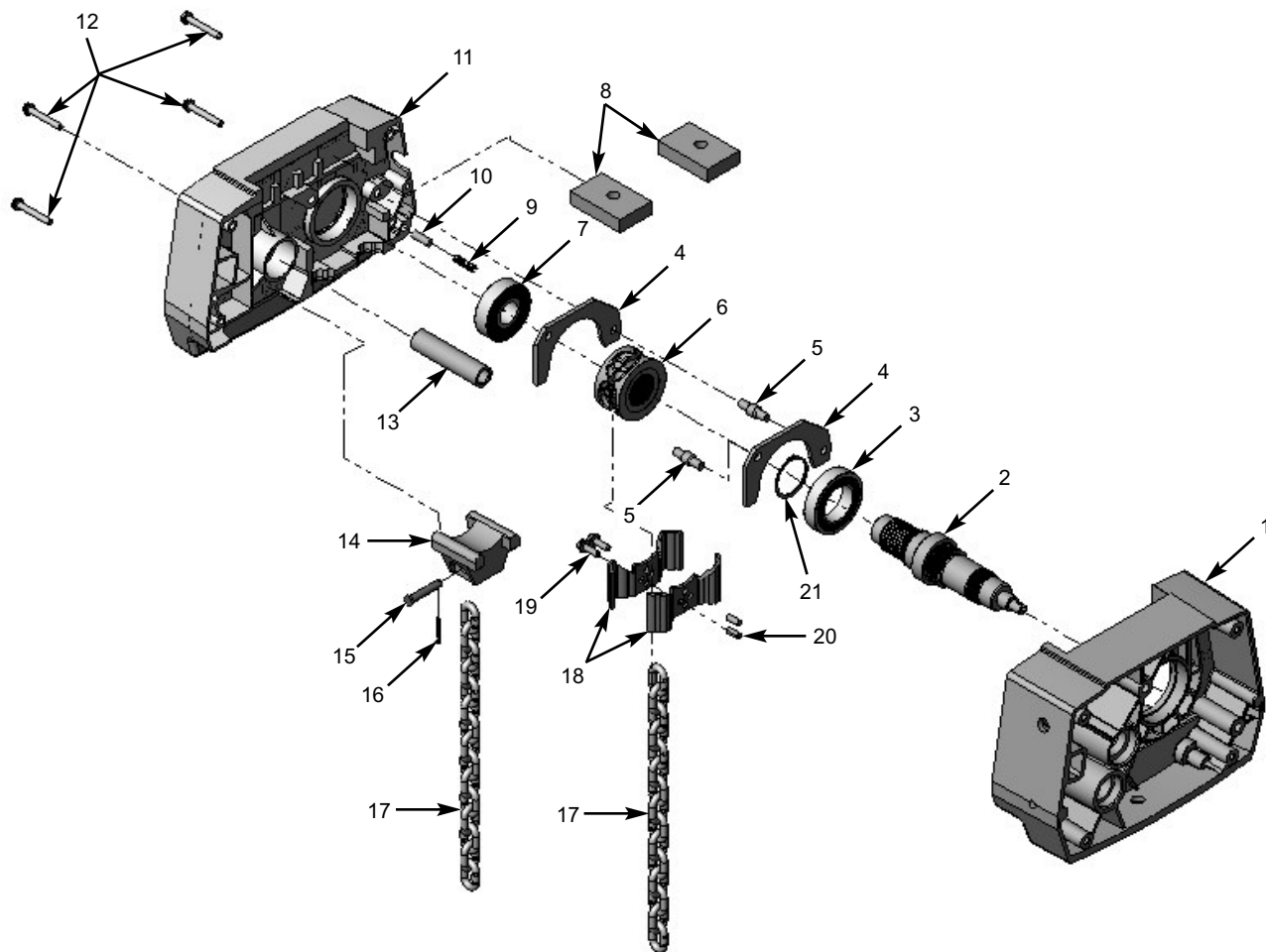

### End Stop Assembly

Consists of Items A, B & C. Refer to Figure 5-4 on Page 11 for correct placement / view on chain - 12 links down from dead end link - Item D.

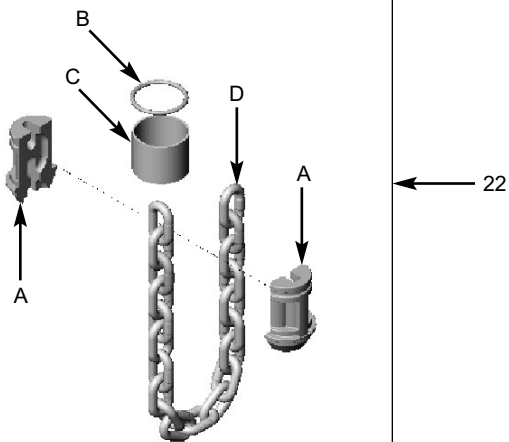

### 3 Ton Model Only

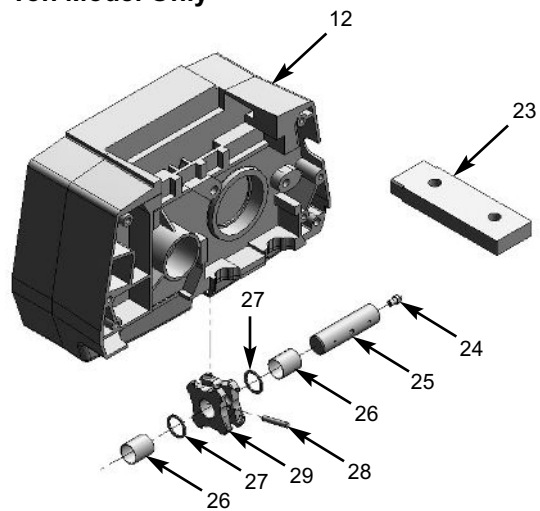

Contact your nearest Coffing Service Center for parts and service. Refer to pages 41 and 42 for a complete list. Please have the hoist model number, serial number, and part number with description available for reference.

Ref. No.	Usage Code	Part Description	Part No.	Qty.
1	E	Transmission Housing	35JG1	1
	D	Transmission Housing	35JG2	1
2		Sheave Shaft		1
3		Bearing	500K29	1
4	E	Chain Guide Plate ( <sup>9</sup> / <sub>32</sub> " Chain)	272J1	2
	D	Chain Guide Plate ( <sup>1</sup> / <sub>4</sub> " Chain)	272J2	2
5		Spacer, Chain Guide Plate	127J1	2
6	D	Sheave ( <sup>1</sup> / <sub>4</sub> " Chain)	16J2	1
	E	Sheave ( <sup>9</sup> / <sub>32</sub> " Chain)	16J1	1
7	D	Bearing	500K28	1
	E	Bearing	500K5	1
8	F, G, H	Retainer Block	170J1	2
9		Spring, Slack End	23J2	1
10		Pin, Slack End	H-5490P	1
11		Sheave Housing (Models EC-2012, EC-2016, EC-4006 and EC-4008)	33J1	1
		Sheave Housing (Models EC-0564 & EC-1032)	33J2	1
		Sheave Housing (Models EC-0516, EC-0532, EC-1009, EC-1016, EC-2004 & EC-2008)	33J2-1	1
		Sheave Housing (Model EC-6005)	33J19	1
12	F, G, H	Screw	H-2978P	1
	J	Screw	H-2232	4
		Screw	H-2976P	4
13	F, G, H	Drive Coupling	107J1	4
	J	Drive Coupling	107JG7-4	1
14	G	Dead End Lug	4J3	1
	G	Dead End Pin	18J1	1
15	G	Cotter Pin	H-5025P	1
16	D	Load Chain ( <sup>1</sup> / <sub>4</sub> " Chain, measured in ft.)	JL19B	1
17	E	Load Chain ( <sup>9</sup> / <sub>32</sub> " Chain, measured in ft)	JL19-1	-
18	D	Chain Guide ( <sup>1</sup> / <sub>4</sub> " Chain)	JF250-3	-
	E	Chain Guide ( <sup>9</sup> / <sub>32</sub> " Chain)	JF254-3	2
19		Screw	H-2976P	2
20		Dowel Pin	H-5382	2
21		Retaining Ring	H-5539	1
22	E	End Stop Assembly ( <sup>9</sup> / <sub>32</sub> " Chain)	75JG6K	1
	D	End Stop Assembly ( <sup>1</sup> / <sub>4</sub> " Chain)	75JG7K	1
23	J	Retainer Block	170J4	2
24	J	Grease Fitting	H-7818	1
25	J	Idler Shaft	122J16	1
26	J	Sleeve Bearing	530J35	1
27	J	Washer	255K31	2
28	J	Grooved Pin	H-5219	1
29	J	Idler Sheave	28J12	1

## Figure 8-7A - Pushbutton, 1-Speed Hoists

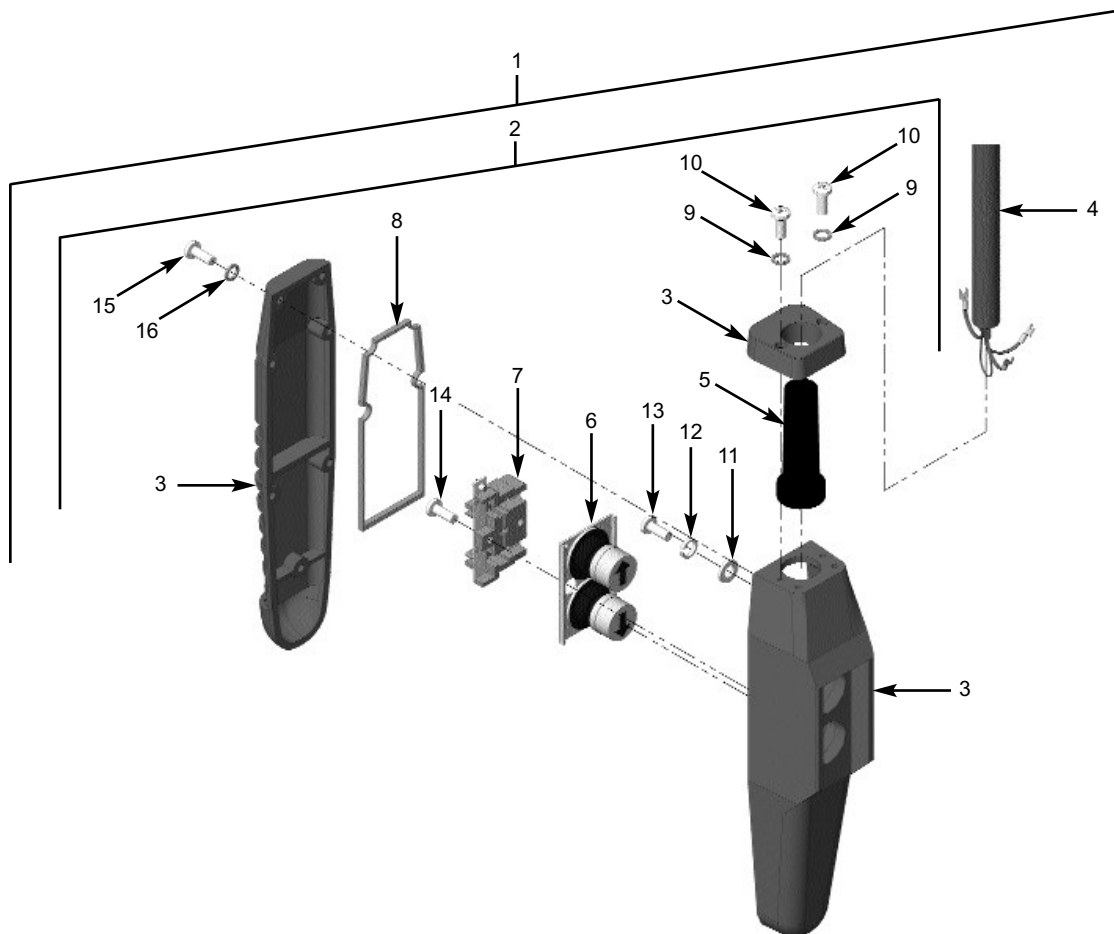

### Parts List for Pushbutton, 1-Speed

Ref. No.	Description	Part No.	Qty.
1	Pushbutton Station and Control Cable Assembly		
	6 ft Cable Length	PB2100-6	1
	11 ft Cable Length	PB2100-11	1
	16 ft Cable Length	PB2100-16	1
2	Pushbutton Station Assembly (2-Button, 1-Speed)	36900R	1
3	Enclosure	36998R	1
4	Control Cable Assembly		
	6 ft Cable Length	PBC2100-6	1
	11 ft Cable Length	PBC2100-11	1
	16 ft Cable Length	PBC2100-16	1
	Special Drop	PBC2100-#	-
5	Grommet	36989	1
6	Button Assembly	36988	1
7	Contact Assembly (includes items 6 & 7)	36987	1
8	Gasket	36986	1
*	Hardware Kit (includes items 9 thru 16)	36939	1
△	Warning Tag	687K3W	1

(△) Not shown.

(#) Length of Cable in Feet (pushbutton drop).

Contact your nearest Coffing Service Center for parts and service. Refer to pages 41 and 42 for a complete list. Please have the hoist model number, serial number, and part number with description available for reference.

## Figure 8-7B - Pushbutton, 2-Speed Hoists

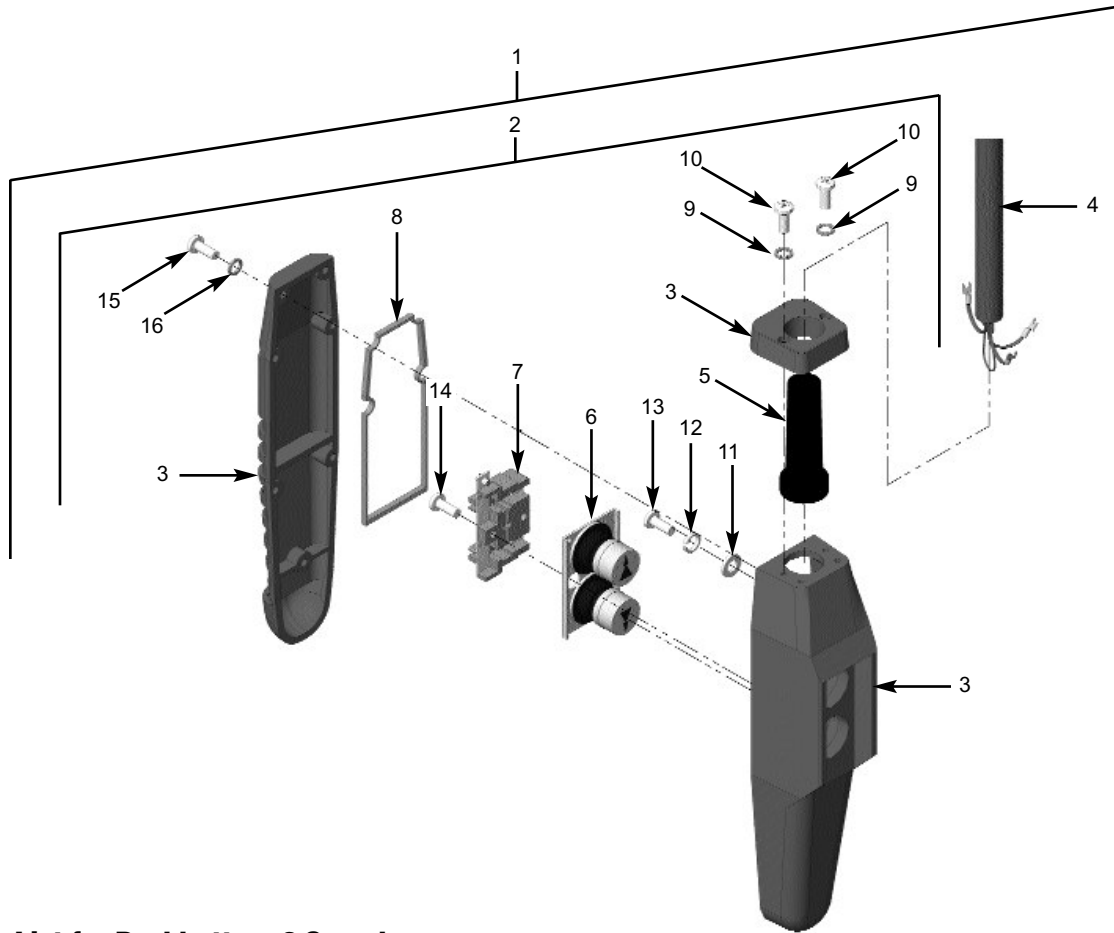

### Parts List for Pushbutton, 2-Speed

Ref. No.	Description	Part No.	Qty.
1	Pushbutton Station and Control Cable Assembly		
	6 ft Cable Length	PB2200-6	1
	11 ft Cable Length	PB2200-11	1
	16 ft Cable Length	PB2200-16	1
2	Pushbutton Station Assembly (2-Button, 2-Speed)	36800R	1
3	Enclosure	36998R	1
4	Control Cable Assembly		
	6 ft Cable Length	PBC2200-6	1
	11 ft Cable Length	PBC2200-11	1
	16 ft Cable Length	PBC2200-16	1
	Special Drop	PBC2200-#	-
5	Grommet	36866	1
6	Button Assembly	-	1
7	Contact Assembly (includes items 6 & 7)	70964	1
8	Gasket	36986	1
*	Hardware Kit (includes items 9 thru 16)	36939	1
△	Warning Tag	687K3W	1

(△) Not shown.

(#) Length of Cable in Feet (pushbutton drop).

## Figure 8-8A - Limit Switch Parts

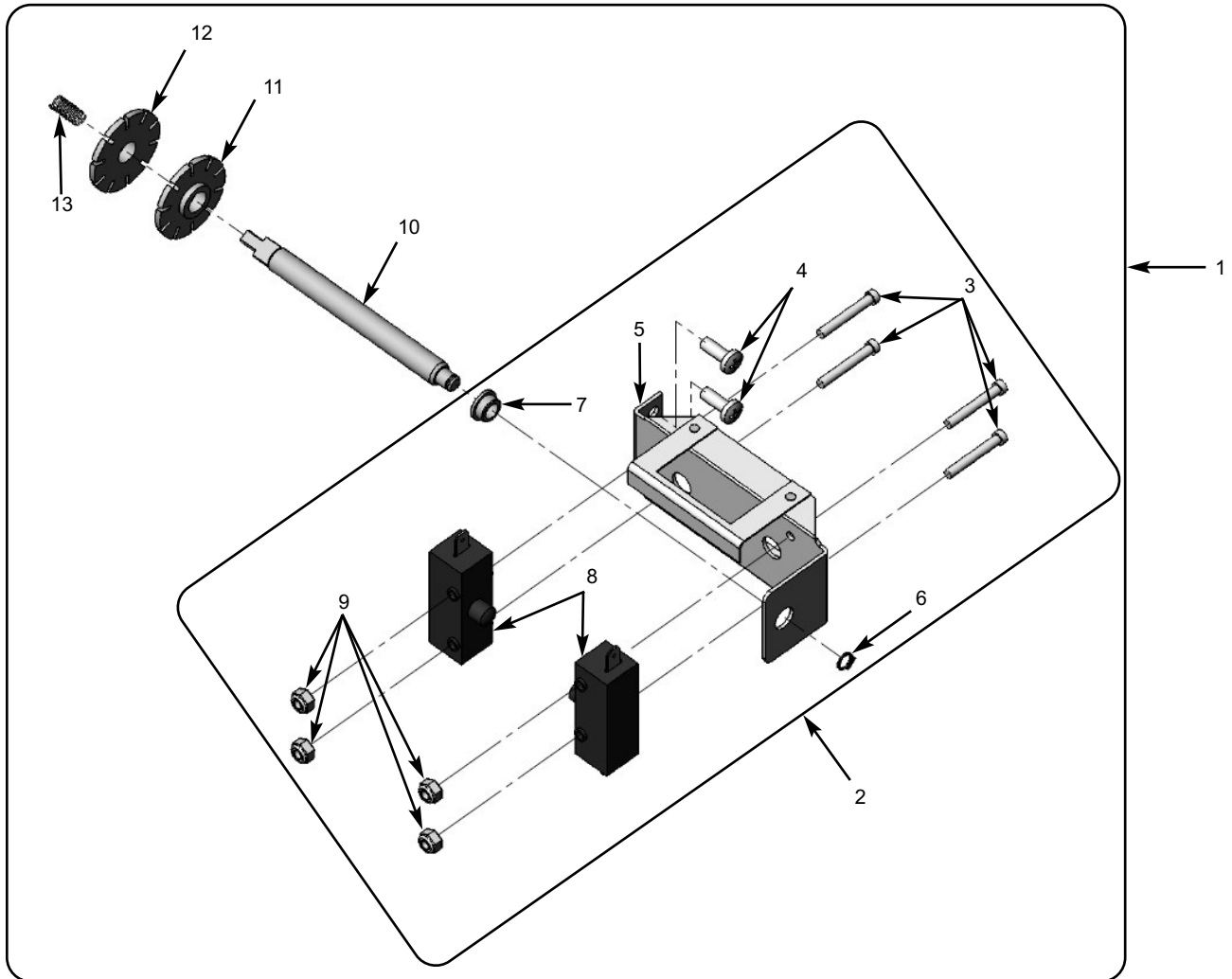

Ref. No.	Description	Part No.	Qty.
1	Limit Switch Assembly (includes items 3-13)	918JG4	1
2	Limit Switch Bracket Assembly (includes items 3-9)	918JG3	1
3	6-32UNC x 1" Screw	H-1402P	4
4	10-24UNC x 1/2" Screw	H-2970	2
5	Limit Switch Bracket (includes item 7)	JF900-3	1
6	Retaining Ring	H-5520	1
7	Bushing	JF531-4	1
8	Switch	815J1	2
9	6-32UNC Elastic Locknut	H-3944	4
10	Limit Switch Shaft	JF117-3S	1
11	Limit Switch Nut (gold)	SK6000-63W	1
12	Limit Switch Nut (silver)	SK6000-63Z	1
13	Spring	JF343-3	1



Contact your nearest Coffing Service Center for parts and service. Refer to pages 41 and 42 for a complete list. Please have the hoist model number, serial number, and part number with description available for reference.

## Figure 8-8B - Long Lift Limit Switch Parts

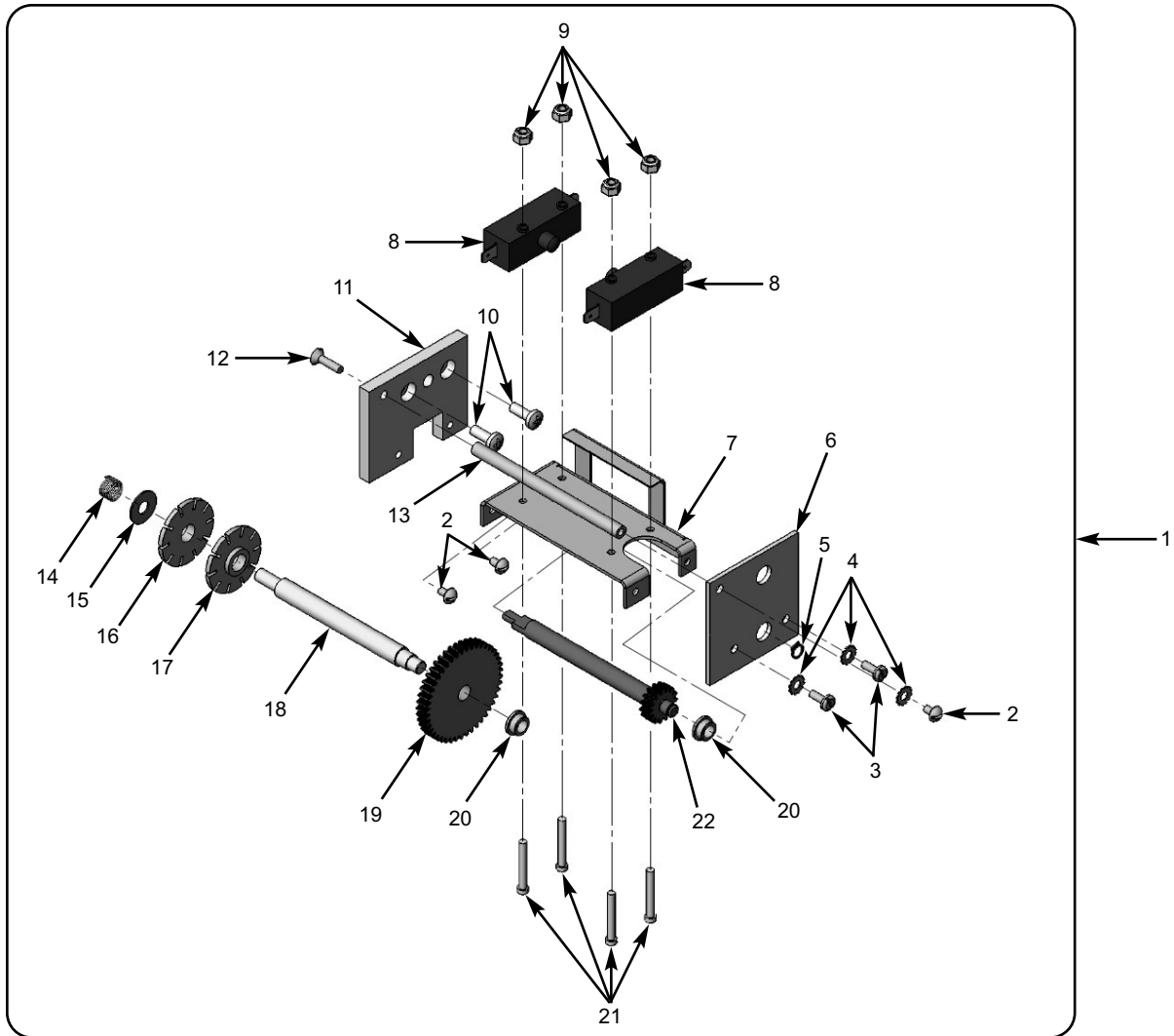

Ref. No.	Description	Part No.	Qty.	Ref. No.	Description	Part No.	Qty.
1	Limit Switch Assembly (includes 2-20)	944JG6	1	13	Post	110J14	1
2	8-32UNC x 1/4" Screw	854823	3	14	Spring	PB287	1
3	8-32UNC x 3/8" Screw	H-2741P	2	15	Thrust Washer	255K16	1
4	#8 External-tooth Lockwasher	H-4158	3	16	Limit Switch Nut (gold)	SK6000-63W	1
5	Retaining Ring	H-5520	1	17	Limit Switch Nut (silver)	SK6000-63Z	1
6	End Plate	258J8	1	18	Limit Switch Shaft	117J2S	1
7	Frame and Guide Assembly	258JG7	1	19	Limit Switch Gear	428J2	1
8	Switch	815J1	2	20	Bushing	JF531-4	2
9	6-32UNC Elastic Locknut	H-3944	4	21	6-32UNC x 1" Screw	H-1402P	4
10	10-24UNC x 3/8" Screw	H-2981P	2	22	Limit Switch Drive	427J1	1
11	Mounting Plate	129J1	1	*	Limit Switch Shaft and Gear (includes 18 & 19)	117JG2	-
12	8-32UNC x 1/2" Screw	H-1210	1				

## Figure 8-9 - Motor Brake Parts

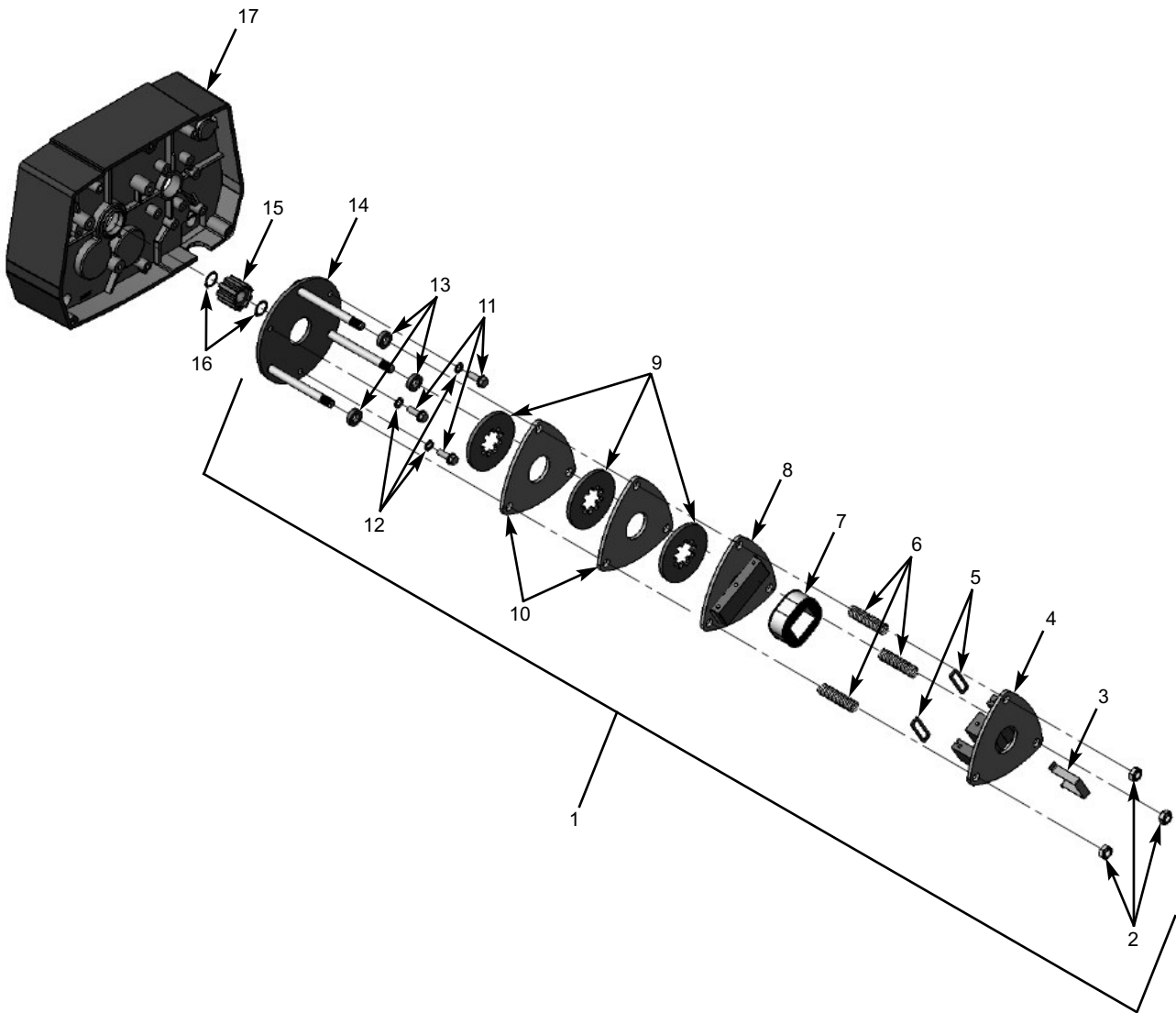

Contact your nearest Coffing Service Center for parts and service. Refer to pages 41 and 42 for a complete list. Please have the hoist model number, serial number, and part number with description available for reference.

Ref. No.	Usage Code	Part Description	Part No.	Qty.
1	A	Disc Brake Assembly (¼ & ½ hp, 115/230 V Hoists) (includes items 2-14)	854JG6	1
	A	Disc Brake Assembly (¾ & 1 hp, 115/230 V Hoists) (includes items 2-14)	854JG1	1
	B	Disc Brake Assembly (¼ & ½ hp, 230/460 V Hoists) (includes items 2-14)	854JG7	1
	B	Disc Brake Assembly (¾ & 1 hp, 230/460 V Hoists) (includes items 2-14)	854JG2	1
	C	Disc Brake Assembly (¼ & ½ hp, 230 V Hoists) (includes items 2-14)	854JG7	1
	C	Disc Brake Assembly (¾ & 1 hp, 230 V Hoists) (includes items 2-14)	854JG2	1
	C	Disc Brake Assembly (¼ & ½ hp, 460 V Hoists) (includes items 2-14)	854JG8	1
	C	Disc Brake Assembly (¾ & 1 hp, 460 V Hoists) (includes items 2-14)	854JG3	1
	B,C	Disc Brake Assembly (¼ & ½ hp, 575 V Hoists) (includes items 2-14)	854JG9	1
	B,C	Disc Brake Assembly (¾ & 1 hp, 575 V Hoists) (includes items 2-14)	854JG4	1
	B,C	Disc Brake Assembly (¼ & ½ hp, 208 V Hoists) (includes items 2-14)	854JG10	1
	B,C	Disc Brake Assembly (¾ & 1 hp, 208 V Hoists) (includes items 2-14)	854JG5	1
2		Locking Nut	H-3978	3
3		Retainer	JF-710	1
4		Plate & Frame Assembly (includes item 5)	857JG1	1
5		Shading Coil Element (must be attached to frame with H7812 adhesive)	860J1	2
6		Spring	344J6	3
7	A	Coil (115V, 60Hz, for Brake 854JG1 & 854JG6)	JF-853-1	1
	B,C	Coil (230V, 60Hz, for Brake 854JG2 & 854JG7)	JF-853-2	1
	C	Coil (460V, 60Hz, for Brake 854JG3 & 854JG8)	JF-853-3	1
	B,C	Coil (575V, 60Hz, for Brake 854JG4 & 854JG9)	JF-853-4	1
	B,C	Coil (208V, 60Hz, for Brake 854JG5 & 854JG10)	JF-853-5	1
8		Plate & Armature Assembly	858JG1	1
9		Brake Disc 1/4 & 1/2 HP	581J1A	2
		Brake Disc 1 HP	581J1A	3
10		Brake Plate	291J1	2
11		Screw	H-2976P	3
12		Lockwashers	H-4134	3
13		Spacer (¼ & ½ hp Models Only)	141J2	3
14		Plate & Stud Assembly	859JG1	1
15		Brake Adapter	142J1	1
16		Retaining Ring	H-5501	2
17		Transmission Cover (Ref. Figure 8-1)	34JG1	1
△		Decal, Load Equalizer	676J1	-
△		Adhesive (1-oz. Tube)	H-7812	-

(△) Not shown.

## Figure 8-10 - Bottom Block Assemblies

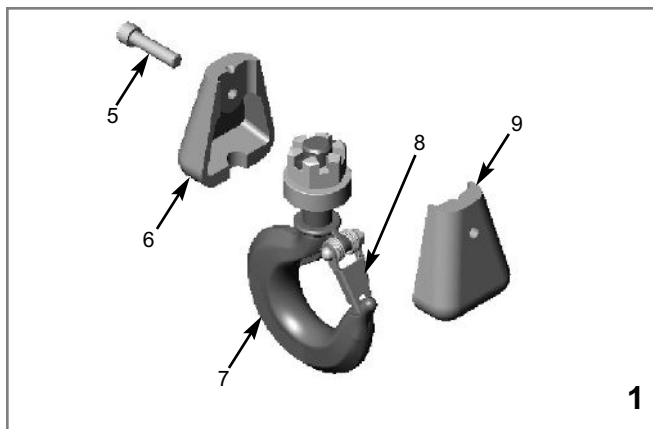

1/2 Ton & Under Models

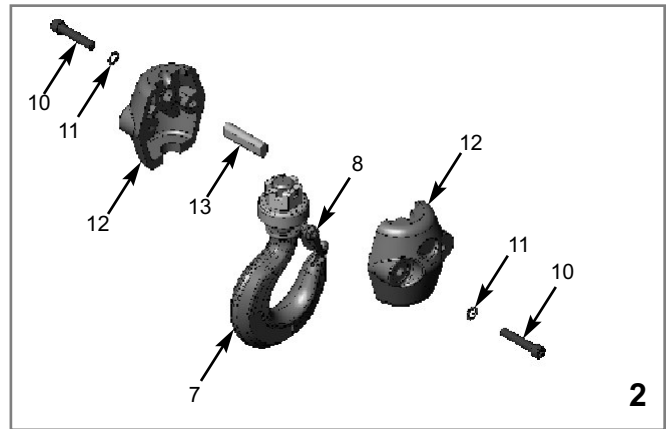

1 Ton Models

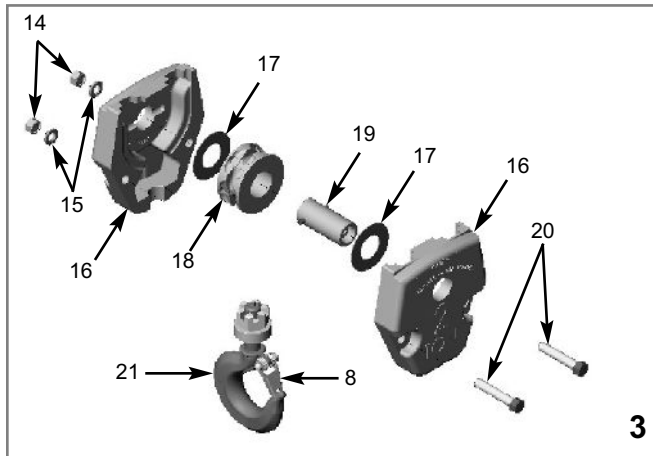

Double-Chained Models

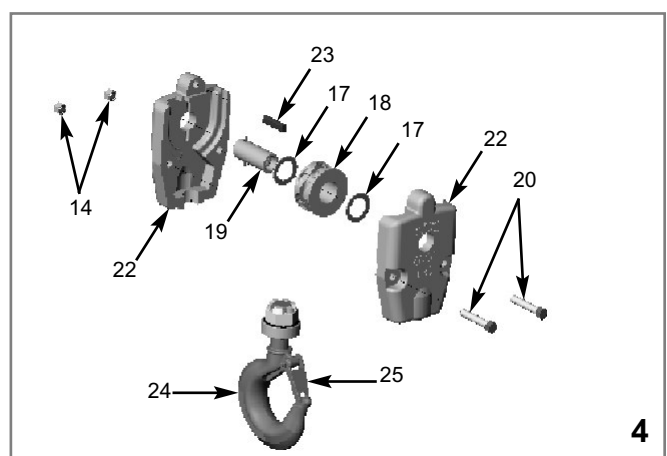

Triple-Chained Models

Ref. No.	Description	Part No.	Usage Code	Ref. No.	Description	Part No.	Usage Code
1	Bottom Block Assembly	913JG4AS	F	15	Lock Washer	H-4085P	G
2	Bottom Block Assembly	913JG3AS	H	16	Frame (Models EC-2004 & EC-2008)	30J2	G
3	Bottom Block Assembly	914JG2	G		Frame (Models EC-4006 & EC-4008)	30J4	G
	Bottom Block Assembly	914JG4	G	17	Washer	255K2	G,J
4	Bottom Block Assembly	914JG23	J	18	Sheave & Bushing Assembly (Models EC-2004 & EC-2008)	16JG7	G
5	Screw	JF700	F		Sheave & Bushing Assembly (Models EC-4006, EC-4008 & EC-6005)	16JG6	G,J
6	Frame	JF20-2	F	19	Shaft Assembly	122JG3	G,J
7	Hook & Latch Assembly	3JG20S	F,H	20	Screw	H-2403P	G,J
8	Latch Kit	4X1304	F,H	21	Hook & Latch Kit	3KG1	G
9	Frame	JF20-3	F		Hook & Latch Kit	3KG6	G
10	Screw	S49-77	H	22	Frame (Model EC-6005)	30J20	J
11	Lock Washer	H-4134	H	23	Dead End Pin	18J8	J
12	Frame	30J14	H	24	Hook & Latch Assembly	3JG14S	J
13	Dead End Pin	18J8	J	25	Latch Kit	4X1307	J
14	Hex Nut	H-3473P	G				
	Hex Nut	H-3964P	J				

Contact your nearest Coffing Service Center for parts and service. Refer to pages 41 and 42 for a complete list. Please have the hoist model number, serial number, and part number with description available for reference.

## Figure 8-11 - Chain Container Parts

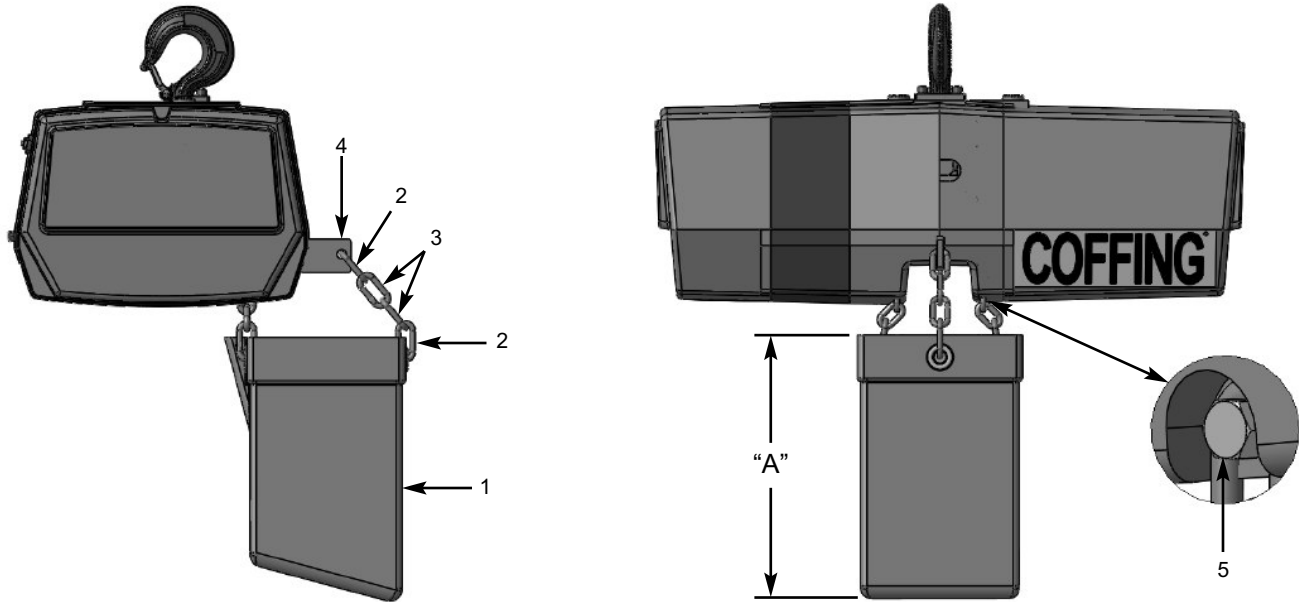

EC1 CHAIN CONTAINER "A"					
CHAIN CONTAINER	CHAIN CONTAINER KIT	DIMENSION (in.)	CAPACITY (IN FEET PER HOIST LIFT)		
			1-CHAIN SINGLE	2-CHAIN DOUBLE	3-CHAIN TRIPLE
FOR SMALL FRAME EC MODELS EC-0516 - EC-6005 (EXCEPT EC-2032) AND ALL ED MODELS					
927J17	927JG17	10 7/16	20	10	N/A
927J18	927JG18	12 1/2	25	12 1/2	N/A
927J19	927JG19	16	35	17 1/2	12
927J20	927JG20	20 1/4	50	25	17
927J202A	927JG202A	20	75	37	25
927J203A	927JG203A	24	100	50	33
927J204A	927JG204A	35	150	75	50

Ref. No.	Description	Part No.	Qty.
1	Chain Container	See Chart Above	1
2	Split Link	H-7929	4
3	Chain Link	53J4	3
4	Mounting Arm	267J3	1
5	Screw, 1/4 -20UNC x 3/4"	H-2349	2
*	Chain Container Kit (includes items 1-5)	See Chart Above	-

---

## Do's and Do Not's

---

### Electric and Air Powered Hoists

The following warnings and operating practices have been taken from *American National (Safety) Standard ANSI B30.16* and are intended to avoid unsafe hoisting practices which might lead to personal injury or property damage. These recommendations apply to all electric and air powered hoists for vertical lifting service involving material handling of freely suspended unguided loads.

#### WARNING: TO AVOID INJURY:

1. **DO** read ANSI B30.16 Safety Standard for Overhead Hoists and Hoist Manufacturer's Operating and Maintenance Instructions.
2. **DO** be familiar with hoist operating controls, procedures and warnings.
3. **DO** make sure hook travel is in the same direction as shown on controls.
4. **DO** make sure hoist limit switches function properly.
5. **DO** maintain firm footing when operating hoist.
6. **DO** make sure that load slings or other approved sling attachments are properly sized and seated in the hook saddle.
7. **DO** make sure that the hook latch, if used, is closed and not supporting any part of the load.
8. **DO** make sure that load is free to move and will clear all obstructions.
9. **DO** take up slack carefully, check load balance, lift a few inches and check load holding action before continuing.
10. **DO** avoid swinging of load or load hook.
11. **DO** make sure that all persons stay clear of the suspended load.
12. **DO** warn personnel of an approaching load.
13. **DO** protect wire rope and load chain from weld spatter or other damaging contaminants.
14. **DO** promptly report any malfunction, unusual performance, or damage of the hoist.
15. **DO** inspect hoist regularly, replace damaged or worn parts, and keep appropriate records of maintenance.
16. **DO** use the hoist manufacturer's recommended parts when repairing a hoist.
17. **DO** use hook latches wherever possible.
18. **DO** apply lubricant to the wire rope or load chain as recommended by the hoist manufacturer.
19. **DO NOT** lift more than rated load.
20. **DO NOT** use the hoist load limiting device to measure the load.
21. **DO NOT** use damaged hoist or hoist that is not working correctly.
22. **DO NOT** use the hoist with twisted, kinked, damaged or worn wire rope or chain.
23. **DO NOT** lift a load unless wire rope is properly seated in its groove(s) or unless chain is properly seated in chainwheel (s) or sprocket(s).
24. **DO NOT** use load rope or load chain as a sling or wrap rope or chain around the load.
25. **DO NOT** lift a load if any binding prevents equal loading on all supporting ropes or chains.
26. **DO NOT** apply the load to the tip of the hook.
27. **DO NOT** operate unless load is centered under hoist.
28. **DO NOT** allow your attention to be diverted from operating the hoist.
29. **DO NOT** operate the hoist beyond limits of load rope or load chain travel.
30. **DO NOT** use limit switches as routine operating stops unless recommended. They are emergency devices only.
31. **DO NOT** use hoist to lift, support or transport people.
32. **DO NOT** lift loads over people.
33. **DO NOT** leave a suspended load unattended unless specific precautions have been taken.
34. **DO NOT** allow sharp contact between two hoists or between hoist and obstructions.
35. **DO NOT** allow the rope, chain or hook to be used as a ground for welding.
36. **DO NOT** allow the rope, chain or hook to be touched by a live welding electrode.
37. **DO NOT** remove or obscure the warnings on the hoist.
38. **DO NOT** adjust or repair a hoist unless qualified to perform hoist maintenance.
39. **DO NOT** attempt to lengthen the load rope or chain or repair damaged load rope or chain.

Contact your nearest Coffing Service Center for parts and service. Refer to pages 41 and 42 for a complete list. Please have the hoist model number, serial number, and part number with description available for reference.

---

## NOTES

---

# COFFING<sup>®</sup>

## HOISTS



---

## NOTES

---

# COFFING<sup>®</sup>

## HOISTS





Contact your nearest Coffing Service Center for parts and service. Refer to pages 41 and 42 for a complete list. Please have the hoist model number, serial number, and part number with description available for reference.

---

## NOTES

---

# COFFING<sup>®</sup>

## HOISTS



## COFFING AUTHORIZED WARRANTY REPAIR CENTERS AND PARTS DEPOTS

As a Coffing Hoist user, you are assured of reliable repair and parts services through a network of Master Parts Depots and Service Centers that are strategically located across the United States, its territories and Canada. These facilities have been selected on the basis of their demonstrated ability to handle all parts and repair requirements promptly and efficiently.

Below is a list of the Coffing Authorized Warranty Repair Centers and Parts Depots located in United States, its territories and Canada. To quickly obtain the name of a Service Center located nearest you, call (800) 477-5004. Fax: (800) 374-6853. In the following list, the Canadian Service Centers are indicated.

### UNITED STATES

#### ALABAMA

\*\*Tool Smith Co.  
1300 4th Ave.S.  
Birmingham, AL 35233  
(205) 323 2576 (800) 317 8665  
Fax (205) 323 9060

#### ARKANSAS

\*\*Hi Speed Hoist & Crane  
701 N. Maple St. N.  
Little Rock AR 72114  
(501) 375 9178  
Fax (501) 375-4254

#### ARIZONA

\*\*Mechanics Tool Service  
1301 E. Apache Park Place  
Tucson, AZ 85714  
(520) 889 8484 AZ only (800) 372 6700  
Fax (520) 889 6668

#### CALIFORNIA

\*\*Arrow Crane Hoist Corp.  
12714 South Carmenita Road  
Santa Fe Springs, CA 90670  
(562) 921 8328  
Fax (562) 921 9307

\*\*IDG. California  
6842 Walker St.  
La Palma, CA 90623  
(714) 994 6960 (800) 464-5669  
Fax (714) 521 0208

\*\*CraneWorks, Inc.  
2585 Nicholson Street  
San Leandro, CA 94577  
(510) 357-4000  
Fax (510) 357 4099

#### COLORADO

\*\*Crane Repair Co.  
3880 S.Kalamath St.  
Englewood, CO 80125  
(303) 791 7918 (800) 878 7918  
Fax (303) 791 7179

#### FLORIDA

\*\*J. Herbert Corp.  
1751 S. John Young Parkway.  
Kissimmee, FL 34741  
(407) 846 0588 (800) 255- 0588  
Fax (407) 846 8042

\*\*Consolidated Rigging & Marine Sup.  
4700 North Pearl St.  
Jacksonville, FL 32206  
(904) 765 7177 (800) 445 8965  
Fax (904) 765 2056

#### GEORGIA

\*\*Ace Industries Inc.  
6295 McDonough Drive  
Norcross, GA 30093  
(770) 441 0898 (800) 733 2231  
Fax (800) 628 3648

#### ILLINOIS

\*\*Illinois Crane  
1621 West Chanute Rd  
Peoria, IL 61615  
(309) 692 0856 (800) 642 7478  
Fax (309) 692 1034

\*S & K Air Power  
317 DeWitt Ave. East  
Mattoon, IL 61938  
(217) 258 8500 (IL only)-(800) 955  
8501) Fax (217) 258 8571

\*\*Sievert Electric Service  
1230 South Hannah  
Forest Park, IL 60130  
(708) 771 1600 (800) 322 9144  
Fax (708) 771 3124

#### INDIANA

\*\*Brehob Corp.  
1334 S. Meridian St.  
Indianapolis, IN 46225  
(317) 231-8080 (800) 632 4451  
Fax (317) 231 8072

\*\*Materials Handling Equipment  
7433 US 30 East  
Fort Wayne, IN 46803  
(260) 749 0475 (800) 443 6432  
Fax (260) 749 0481

#### IOWA

\*\*Hupp Electric Motors  
275 33rd Ave. S.W.  
Cedar Rapids, Iowa 52404  
(319) 366-0761 (888) 366 0761  
Fax (319) 491 8222

#### KENTUCKY

\*\*Advanced Sherman  
330 North Spring St.  
Louisville, KY 40206  
(502) 896 2166 (877-896-1860)  
Fax (502) 897 9837

#### MASSACHUSETTS

\*\*Abel Distributors, Inc.  
50 Parker Street Unit 2  
Newburyport, MA. 01950  
(978) 463-0700  
Fax: (978) 463-5200

#### MICHIGAN

\*Commercial Group  
9955 Grand River  
Detroit, MI 48204  
(313) 931 6100 (800) 931 7701  
Fax (313) 491 1753

\*\*Continental Crane & Service Co.  
33681 Groesbeck Hwy.  
Fraser, MI 48026  
(586) 293 3870  
Fax (586) 293 0017

#### MICHIGAN cont'd

\*\*Stewart Engineering & Sales  
2140 Aurora Ave.  
Muskegon, MI 49442  
(231) 767 2140  
Fax (231) 767 2233

#### MINNESOTA

\*\*Electric Motor Repair, Inc.  
2010 N. 4th St.  
Minneapolis, MN 55411  
(612) 522 3318 (800) 345 0198  
Fax (612) 588 1617

\*\*J & B Equipment  
8200 Grand Ave. South  
Bloomington, MN 55420  
(952) 884-2040  
Fax (952) 346-1139

\*\*Perfection Crane & Hoist Inc.  
201 DeGraff Ave.  
Swanville, MN 56382  
(320) 547-2401 (800) 253 -6829  
Fax (800) 353 -2254

\*\*Total Tool Supply  
315 N. Pierce St.  
St. Paul, MN 55104  
(952) 646 4055 (800) 444-4899  
Fax (952) 646-8610

#### MISSOURI

\*\*Hertz Equipment Rental & Supply  
800 E. 18th St.  
Kansas City, MO 64108  
(816) 221 7788 (800) 669 7788  
Fax (816) 221 0817

\*\*Zeller Electric  
4250 Hoffmeister  
St. Louis, MO 63125  
(314) 638 9641 Outside MO (800) 530  
5810 Fax (314) 638-6318

\*\*Handling Systems Inc.  
11678 Gravois Rd.  
St. Louis, MO 63126  
(314) 842 7263  
Fax (314) 842-5041

#### MONTANA

\*\*Power Service of Montana, Inc.  
4025 1st. Ave. South  
Billings, Montana 59101  
(406) 252 8114 (800) 823 8665  
Fax (406) 259 3956

#### NEW JERSEY

\*\*Sissco  
186 Route 206 South  
Hillsborough, NJ 08844  
(908) 359 9767 (800) 392 0146  
Fax (908) 359 9773

**UNITED STATES**

**NEW YORK**

\*\*ABC Electric  
24 25 46th Street.  
Long Island City, NY 11103  
(718) 956 0000 (N.Y. only-800-562  
1919) FAX (718) 956 4455

\*\*Beaton Industrial, Inc.  
6083 Trenton Rd.  
Utica, NY 13502 (Ross)  
(315) 797 9346 (N.Y. only-800-724  
4052) Fax (315) 797 9321

\*\*Volland Electric Equipment Co.  
75 Innsbruck Drive  
Buffalo, NY 14227  
(716) 656 9900  
Fax (716) 656 8899

\*\*Kistler Equipment Co.  
4437 S 139th. Street, Omaha NE  
68137  
(402) 896 9090 (866-554 9433) FAX  
(402) 896 9474

**NORTH CAROLINA**

\*\*Carolina Hoist  
3310 E. Wendover Avenue  
Greensboro, NC 27405  
(336) 375 6050 (800) 326 3655  
Fax (336) 375 6053

\*\*Team SESCO  
2225 Freedom Drive  
Charlotte, NC 28208  
(704) 372- 4832 (800) 487 3726  
Fax (704) 342 2604

**OHIO**

\*\*Crane America – Hoist Warehouse  
3351 Obco Court  
Dayton, OH 45414  
(937) 853 1342 (800) 331 5326  
Fax (937) 853 1343

\*\*Americrane & Hoist Corp.  
13224 Enterprise Ave.  
Cleveland, OH 44135  
(216) 267 9100 (800) 652 1932  
Fax (216) 267 9131

\*Samsel Supply Co.  
1285 Old River Rd.  
Cleveland, OH 44113  
(216) 241 0333 (800) 892 8012  
Fax (216) 241 3426

**OREGON**

\*General Tool & Supply Co.  
2705 N.W. Nicolai  
Portland, OR 97210  
(503) 226 3411 (800) 783 3411  
Fax (503) 778 5518

**PENNSYLVANIA**

\*\*Globe Electric Co.  
200 23rd St.  
Pittsburgh, PA 15215  
(412) 781 2677 (800) 850-4440  
Fax (412) 781 1812

\*Keystone Crane & Hoist Co.  
861 S. Washington Rd.  
McMurray, PA 15317  
(724) 746 5080  
Fax (724) 746 5082

**PENNSYLVANIA cont'd**

\*\*McDall Corp.  
475 East Church Rd.  
King of Prussia, PA 19406  
(610)-277-5484 (800)-626-2325  
Fax (610)-277-4690

\*\*Repair Unlimited  
1730 Rockwell Rd.  
Abington, PA 19001  
(215) 657 3335 (800) 369 5891  
Fax (215) 784 0343

**RHODE ISLAND**

\*\*Motors, Hoist & Controls Inc.  
179 Railroad Street  
Woonsocket, RI 02895  
(401) 767 4568  
Fax (401) 767 4567

**SOUTH CAROLINA**

\*\*Engineered Systems, Inc.  
1121 Duncan – Reidville Rd.  
Duncan, SC 29334  
(864) 879 7438 (800) 879 7438  
Fax (864) 848 3143

**TENNESSEE**

\*\*Hoist & Crane Co.  
2508 Perimeter Place  
Nashville, TN 37214  
(615) 242 3383 (888)-464-7811  
Fax (615) 255- 4379

\*\*Hi Speed Electrical Co.  
3013 Thomas Street  
Memphis, TN 38127  
(901) 357 6231  
Fax (901) 357 6238

**TEXAS**

\*\*Abel Equipment Co., Inc.  
3710 Cavalier Drive  
Garland, TX 75042  
(972) 272 7706  
Fax (800) 272 2235

\*\*Gaffey, Inc.  
4922 Northeast Parkway  
Ft. Worth, TX 76106  
(817) 281 1994 (800) 284 4233  
Fax (817) 581 7831

\*\*Gaffey, Inc.  
4003 S. County Rd. 1297  
Odessa, Tx. 79765  
(915) 563 2897 (800) 733 0006  
Fax (915) 563 4703

\*\*Gaffey, Inc.  
1436 N. Duck Creek Rd.  
Cleveland, TX 77327  
(281) 443 6690 (800) 233 8179  
Fax (281) 592 6984

\*\*Hydraulic Equipment Ser.  
1021 N. San Jacinto St.  
Houston, TX 77002  
(713) 228-4073  
Fax (713) 228-0931

**UTAH**

\*\*Rocky Mountain Wire Rope & Rig.  
2421 South 2570 West  
Salt Lake City, UT 84119  
(801) 972 4972 (800) 615 3193  
Fax (801) 974 0621

**VIRGINIA (Richmond Area)**

\*\*Foley Material Handling Co.  
11327 Va. Crane Dr.  
Ashland, VA 23005  
(804) 798 1343  
Fax (804) 798 7843

**WISCONSIN**

\*\*Alferi Industrial Sales & Service  
346 Smith Street  
Neenah, WI 54956  
(920) 722 6483  
Fax (920) 722 6489

\*Lift Inc.  
6667 W. Mill Rd.  
Milwaukee, WI 53218  
(414) 353 5353 (800) 728 5438  
Fax (414) 353- 4444

\*\*Trester Hoist & Equipment  
W136 N4863 Campbell Dr. Suite #  
4. Menomonee Falls, WI 53051  
(262) 790 0700 (800) 234 6098  
Fax (262) 790- 1009

**U. S. Territories ( Puerto Rico )**

\*\*Airequipo Inc.  
Ave. Lopategui Final # 5  
San Juan, P.R. 00936-1918  
(787) 720 8731  
Fax (787) 720- 8395

**CANADA**

**ALBERTA**

\*\*Kristian Electric  
4215-64 Avenue SE  
Calgary, Alberta T2C 2C8  
(403) 292-9111

**ONTARIO**

\*\*Toronto Electric  
72 Crockford Blvd.  
Scarborough, Ontario M1R 3C4  
(416) 755-7716

\*\*Pro-Crane Hoist Repairs Inc.  
2050 Speers Road, Unit 2  
Oakville, Ontario L6L 2X8  
(905) 825-2586

**QUEBEC**

\*\*Leger  
7995 17th Avenue  
Montreal, Quebec H1Z 5R2  
(514) 376-3050

\*Uptown Ltee  
460 Hubert Street  
Laval, Quebec H7G 2Y9  
(514) 667 1859

\*\*Precision Crane  
1331 Kebet Way  
Port Coquitlam, BC  
(604) 941-3180

\* PARTS DEPOT & REPAIR CENTERS

\*\* PARTS DEPOT & WARRANTY REPAIR  
CENTER

# COFFING® WARRANTY



Every hoist is thoroughly inspected and performance tested prior to shipment from the factory. If any properly installed, maintained and operated hoist as outlined in the applicable accompanying Coffing Hoists manual develops a performance problem due to defective materials or workmanship as verified by Coffing Hoists, repair or replacement of the hoist will be made to the original purchaser without charge and the hoist will be returned, transportation prepaid. This warranty does not apply where deterioration is caused by

normal wear, abuse, improper or inadequate power supply, improper or inadequate maintenance, eccentric or side loading, overloading, chemical or abrasive actions, excessive heat, unauthorized modifications or repairs, or use of non-Coffing repair parts.

**EXCEPT AS STATED HEREIN, COFFING HOISTS MAKES NO OTHER WARRANTIES, EXPRESS OR IMPLIED, INCLUDING WARRANTIES OF MERCHANTABILITY AND FITNESS FOR A PARTICULAR PURPOSE.**

## **WARNING**

### **Overloading and Improper Use Can Result In Injury**

#### **To Avoid Injury:**

- Do not exceed working load limit, load rating, or capacity.
- Do not use to lift people or loads over people.
- Read and follow all instructions.

## **COFFING® HOISTS**

Coffing Hoists • 2020 Country Club Road • P.O. Box 779 •  
Wadesboro, North Carolina 28170 USA

Tel: 800.477.5003 • Fax: 800.374.6853 • 704.694.6829

[www.coffinghoists.com](http://www.coffinghoists.com)