

COFFING[®]

HOISTS

OPERATING & MAINTENANCE INSTRUCTIONS WITH PARTS LIST

Publication Part No. RA-680-3

RA Ratchet Lever Hoist

For Capacities:

3/4 - 6 Ton

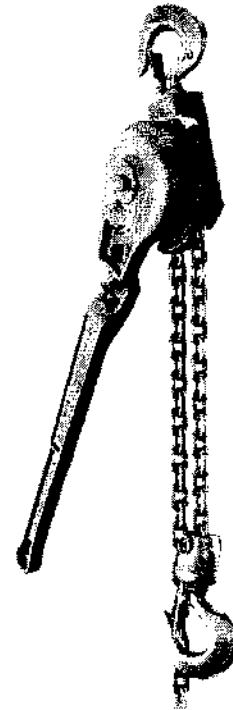

IMPORTANT—CAUTION

To safeguard against the possibility of personal injury or property damage, follow the recommendations and instructions of this manual. This manual contains important information for the correct installation, operation, and maintenance of this equipment. All persons involved in the installation, operation, and maintenance of this equipment should be thoroughly familiar with the contents of this manual. Keep this manual for reference and further use.

▲ WARNING

To prevent personal injury, do not use the equipment shown in this manual to lift, support, or otherwise transport people, or to suspend unattended loads over people.

TABLE OF CONTENTS

SECTION I	INTRODUCTION	3
1-1	General Information	3
1-2	Safety Standards	3
1-3	Hoist Construction and Features	3
1-4	Basic Hoist Data	3
1-5	Application Information	3
1-6	Warranty	3
SECTION II	PREPARATION FOR USE	4
2-1	Safety Notes	4
2-2	Inspection Prior to Initial Use	4
2-3	Installation	4
2-4	Testing	4
SECTION III	OPERATION	4
3-1	General	4
3-2	Safety Notes	4
3-3	Attaching the Load	5
3-4	Lifting or Pulling the Load	5
3-5	Lowering the Load	5
3-6	Free Chaining	5
SECTION IV	INSPECTION	5
4-1	General	5
4-2	Frequent Inspection	5
4-3	Periodic Inspection	6
4-4	Inspection of Hoist Not in Regular Use	6
4-5	Chain Inspection	6
4-6	Hook Throat Opening	7
SECTION V	MAINTENANCE & REPAIR	7
5-1	General	7
5-2	Lubrication	7
5-3	Chain Replacement	8
5-4	Timing Procedure	11
SECTION VI	ILLUSTRATED PARTS LIST	12
6-1	General	12
6-2	How to Use Illustrated Parts List	12
6-3	How to Order Replacement Parts	12
Figure 6-1	RA-15 & RA-20 Basic Hoist	12
Figure 6-2	Suspension Assemblies for RA-15 & RA-20 Series	13
Figure 6-3	RA-30 & RA-40 Basic Hoist	15
Figure 6-4	Top Suspension Assemblies for RA-30 & RA-40 Series	16
Figure 6-5	Bottom Suspension Assemblies for RA-30 & RA-40 Series	17
SECTION VII	DO'S AND DO NOT'S	20

SECTION I INTRODUCTION

1.1 GENERAL INFORMATION

This manual provides information for the safe operation and maintenance of coffering RA Ratchet and Pawl Lever Hoist. All persons operating or maintaining these hoists should be familiar with the information contained herein. Adherence to the precautions, procedures, and maintenance practices described should ensure long reliable operation. Suggestions for improvements to this manual are solicited.

1.2 SAFETY STANDARDS

All person's concerned with the operation, inspection and maintenance of these hoists are urged to observe all applicable state and local codes for this product.

1.3 HOIST CONSTRUCTION

Dual ratchet and pawl design provides easy operation with one pawl always engaged with the ratchet during lifting or lowering operations. The body and handle are built of high-strength aluminum alloy for light weight and corrosion resistance. The open body construction permits easy inspection and maintenance. The handle will operate from either side.

1.4 BASIC HOIST DATA

The operator should be aware of the Basic Hoist Data in Table I.

1.5 APPLICATION INFORMATION

This hoist is intended for general industrial use for lifting, pulling, and tensioning-type applications within its rated load. Prior to installation and operation, the user should review his application for abnormal environmental or handling conditions and to observe the applicable recommendations as follows:

a. **Adverse Environmental Conditions** Do not use the hoist in areas containing flammable vapors, liquids, gases or any combustible dusts or fibers. Refer to Article 500 of *The National Electric Code*. Do not use this hoist in highly corrosive or abrasive environments. Do not use this hoist in applications involving extended exposure to ambient temper-

atures below -10°F or above 130°F .

b. **Lifting of Hazardous Loads** This hoist is not recommended for use in lifting or transporting hazardous loads or materials which could cause wide-spread damage if dropped. The lifting of loads which could explode or create chemical or radioactive contamination if dropped requires fail-safe redundant supporting devices which are not incorporated into this hoist.

c. **Pulling Between Fixed Stops** When operating in the lowering direction with the RA Hoist the load is raised slightly to allow the load pawl to disengage from the ratchet. Avoid applications that will not permit this slight additional lift on the first lowering stroke.

1.6 WARRANTY

Every hoist is thoroughly inspected and tested prior to shipment from the factory. Should any problems develop, return the complete hoist prepaid to your nearest Duff-Norton Authorized Warranty Repair Station. If inspection reveals that the problem is caused by defective workmanship or material, repairs will be made without charge and the hoist will be returned, transportation prepaid.

This warranty does not apply where: (1) deterioration is caused by normal wear, abuse, improper or inadequate power supply, eccentric or side loading, overloading, chemical or abrasive actions, improper maintenance or excessive heat; (2) problems resulted from repairs, modifications or alterations made by persons other than factory or Duff-Norton Authorized Warranty Repair Station personnel; (3) the hoist has been abused or damaged as a result of an accident; (4) repair parts or accessories other than those supplied by Duff-Norton Company are used on the hoist. Equipment and accessories not of the seller's manufacture are warranted only to the extent that they are warranted by the manufacturer. EXCEPT AS STATED HEREIN, DUFF-NORTON COMPANY MAKES NO OTHER WARRANTIES, EXPRESS OR IMPLIED, INCLUDING WARRANTIES OF MERCHANTABILITY AND FITNESS FOR A PARTICULAR PURPOSE.

TABLE I. Basic Hoist Data

Model No.	Rated Capacity Pounds	Standard Lift Inches	Av. Pull on Lever to Lift Full Load Pounds	Approx. Net Wt. Pounds	Min. Distance Between Hooks Inches	Lever Length Inches	Min. Incr. in Lifting Position Inches	Number of Chains
RA-15	1,500	60	59	12- ¹ / ₄	12- ⁷ / ₁₆	20- ¹ / ₂	.451	1
RA-20	2,000	60	79	12- ¹ / ₄	12- ⁷ / ₁₆	20- ¹ / ₂	.451	1
RA-15-2	3,000	60	60	18	17- ¹ / ₄	20- ¹ / ₂	.226	2
RA-15-2W	3,000	60	50	18	17- ¹ / ₈	20- ¹ / ₂	.226	2
RA-30	3,000	60	82	23	13- ³ / ₄	20- ¹ / ₂	.256	1
RA-40	4,000	60	110	23	13- ³ / ₄	20- ¹ / ₂	.256	1
RA-30-2	6,000	60	93	35	17- ¹ / ₄	20- ¹ / ₂	.128	2
RA-30-2W	6,000	60	93	35	18- ³ / ₈	20- ¹ / ₂	.128	2
RA-30-3	9,000	60	96	53	22	20- ¹ / ₂	.085	3
RA-30-4	12,000	60	97	63	22	20- ¹ / ₂	.064	4

SECTION II PREPARATION FOR USE

2.1 SAFETY NOTES

- a. The supporting structure and load attaching devices should have a load rating at least equal to that of the hoist.
- b. This hoist is not suitable for use in locations or areas containing explosive dust, vapors or gases.
- c. The installation area must provide safe operating conditions for the operator, including sufficient room for the operator and other personnel to stand clear of the load at all times.

2.2 INSPECTION PRIOR TO INITIAL USE

Inspect the hoist for any evidence of shipping damage or loose parts. Perform the frequent inspections listed in paragraph 4.2. This should be done by or under the direction of a person familiar with hoist operation and industrial safety standards prior to initial use. All inspections of any kind should be logged or recorded, dated, signed and filed for reference purposes.

2.3 INSTALLATION

- a. Secure the hoist to a suitable supporting member by use of the top hook. Make sure that the hook latch is closed. Apply a small amount of H-7593 grease or equivalent between the hook and supporting member.

CAUTION:

- b. **Do not side load the hoist or restrict the housing or chain from forming a straight line with the direction of loading.**

2.4 TESTING

Check the hoist through a few lifting and lowering cycles with no load on the hook. Attach a load of fifty pounds to the hook and check the hoist through a few lifting cycles. Operate the hoist handle from either side of hoist. If operation is normal with this light load, test the hoist for operation with rated load, and then with about 125 percent of rated load.

SECTION III OPERATION

3.1 GENERAL

This section presents information concerning the proper operation of the Coffing® RA-Series Hoist. It is not intended to serve as a handbook on rigging. Rigging, the process of moving heavy loads using mechanical devices, requires special knowledge and equipment. For information on the safe use of slings and similar rigging gear, users are urged to consult a textbook on rigging.

3.2 SAFETY NOTES

Inspect the hoist for any sign of loose, broken, or malfunctioning parts (see Section IV). Any malfunctioning hoist should be tagged as "out of order" and removed from service until the defect is corrected.

- a. Do not overload the hoist.
- b. Do not use a handle extender (cheater bar). The hoist is designed to lift or pull its rated capacity when a reasonable effort is exerted by one person (see Table I). If effort appears to be excessive, recheck the load and use a larger capacity hoist if necessary.
- c. Do not side load the hoist. Always pull in a straight line between hooks. Side loading over a sharp corner may fracture the hoist housing or load block.
- d. Be sure there are no twists in the load chain and make sure that load chain is free to move and will clear all obstructions. On multiple chained hoist it is possible for the load block to be capsized or turned over one or more times causing the chain to twist.

- e. Do not operate the hoist from an off balance position. Operator should have firm footing or be otherwise secured before operating the hoist.

- f. Before raising or pulling a load, always check to see that it is held securely in the hook or sling chains, etc. Raise the load only until the load chain is taut and then recheck the rigging before continuing to raise the load.

- g. Make sure that the slings and other rigging have sufficient capacity to support the load, and are in good condition.

- h. **DO NOT STAND BENEATH A LOAD!** Do not move a load in such a manner as to endanger personnel.

- i. Do not leave the hoist under load for extended or unattended periods unless specific precautions have been taken to provide protection.

- j. Do not wrap the load chain around a load. **USE A SLING!**

- k. Do not **TIP-LOAD** any hook, as this will exert undue strain in the hook, resulting in hook failure.

- l. The RA Series of hoists are designed for manual operation by one person. Do not attempt to operate hoist with other than the manual power furnished by one person.

- m. **DO NOT USE HOIST TO LIFT, SUPPORT OR OTHERWISE TRANSPORT HUMAN CARGO.**

3.3 ATTACHING THE LOAD

Attach the load to the hook by means of slings or other approved devices. Make sure the slings or other devices are seated properly in the saddle of the hook before lifting. Be sure the hook latch is closed and working properly. Never wrap the load chain around the load.

CAUTION—Do not release the handle while it is under load. Always complete the stroke. You will feel or hear the load pawl seating at the end of the handle stroke. If handle continues to offer resistance and you cannot complete the stroke, continue to hold the handle while it returns to its original position.

3.4 LIFTING OR PULLING THE LOAD

To raise or pull the load, turn the control lever to "Up" position, (See Figure 3-1) then operate the handle. Take note of the following when lifting the load:

a. Lift or pull the load a few inches and check to see that it is well balanced in the sling or other lifting device. Make sure the load chain is not kinked or twisted or that the load does not contact any obstruction.

b. Lift or pull the load to the desired distance. Do not leave the hoist under load for extended or unattended periods unless specific precautions have been taken to provide protection.

3.5 LOWERING THE LOAD

To remove or lower the load, turn control lever to the "Down" position, then operate the handle.

CAUTION: Make sure that the slack end chain is free to move into the housing and will clear all obstructions. Do not extend bottom hook beyond the hoist rated lift. End ring should not be allowed to enter the hoist housing.

3.6 FREE CHAINING

To obtain free chain when there is no load on the hoist, place control lever in the "Down" position. Push the free chain lever in the direction of arrow on the handle. Pull the chain slightly backward through the hoist, then the chain will move freely in either direction.

To take up slack in the chain when there is no load on the hoist, simply pull on the ring end of chain.

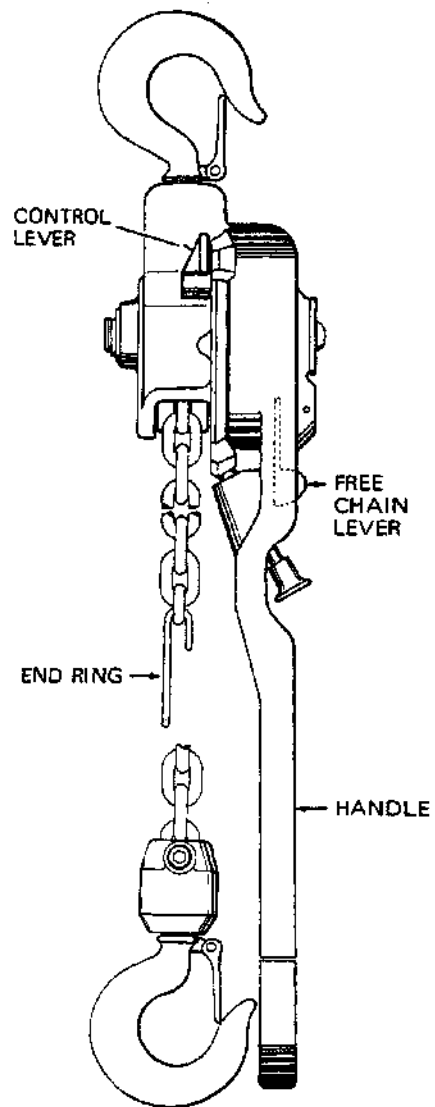

FIGURE 3-1. OPERATION

SECTION IV INSPECTION

4.1 GENERAL

A planned inspection routine should be established for this hoist based upon frequency of use, severity of use, and environmental conditions. Some inspections should be made frequently (daily to monthly) and others periodically (monthly to yearly). It is strongly recommended that an Inspection and Maintenance Check List and an Inspector's Report similar to those shown in Figures 5-5 and 5-6 be used and filed for reference. All inspections should be made by, or under the direction of a designated inspector. Special inspections should be made following any significant repairs or any operating occurrence leading one to suspect that the hoist's capabilities may have been impaired.

The existence of well-worn parts is sufficient reason for questioning safe operation not to mention the added costs to repair damage that will inevitably result if severe wear is permitted to continue. The parts most likely to first evidence wear are: the bushing type bearings for the sheave and pinion

shafts; the handle bearing; the sheaves and their shafts and bushings; thrust bearings and washers for the hooks; pawls, ratchets and gears, the reverse ring and cam; swivel frames and blocks; and the chain and hooks.

4.2 FREQUENT INSPECTIONS

CAUTION: Any unsafe condition disclosed by the inspection shall be corrected before operation of the hoist is resumed. Adjustments and repairs shall be done only by designated personnel.

Perform the following inspections daily prior to initial use of the hoist. Also, observe during operation for any damage which might appear between regular inspections. Prior to inspection, clean parts as required.

a. Inspect the hooks for deformations, chemical damage or cracks. Hooks damaged by chemicals, deformation or cracks, or having throat openings greater than the "Maximum Allowable Opening" shown in Figure 4-2 must be

replaced. If the hook is twisted more than 10 degrees from the plane of the unbent hook, it must be replaced.

NOTE: Any hook that is twisted or has throat openings in excess of those listed in Figure 4-2 indicates abuse or overloading of the hoist. Other load bearing components should be inspected accordingly.

- b. Check for missing, bent or otherwise damaged hook latches.
- c. Check that hooks swivel freely.
- d. Check the hoist handle for bends. If the handle is bent, the hoist has probably been highly overloaded. A qualified service man should inspect the hoist for other damage or return the hoist to the factory.
- e. Check load chain for gouges, nicks, weld spatter, corrosion and distorted links. Also check the chain for presence of foreign material and adequate lubrication.
- f. Check load chain reeving per figure 5-4 making sure that there are no twists in the load chain.
- g. Check that the dead end ring or connection is secure.

4.3 PERIODIC INSPECTIONS

It is recommended that the following inspections be performed at one- to twelve-month intervals. The exact period of inspection will depend on frequency and type of usage. Determination of this period will be based on the user's experience. It is recommended that the user begin with a monthly inspection and extend the periods to quarterly, semi-annually or annually based on his monthly experience.

- a. Perform all the frequent inspections listed in paragraph 4-2.
- b. Check nuts, bolts and other hardware for looseness, stripped or damaged threads.
- c. Check load sheave and chain attachments for distortion, cracks and excessive wear.
- d. Check pawls for excessive wear, binding and worn bearing.
- e. Check reverse ring spring for breaks, corrosion and stretch.
- f. Check pawl stud for excessive wear and pawl retention.
- g. Inspect gear and pinion shaft for adequate lubrication, cracks, distortion, worn or broken teeth and damaged threads.
- h. Inspect bearings for adequate lubrication, distortion, cracks and excessive wear.
- i. Check housing, covers and swivel frames for cracks, distortion and damaged threads.
- j. Inspect the chain per paragraph 4-5.
- k. Check hooks for cracks using dye penetrant, magnetic particle or other suitable detection method.

4.4 INSPECTION OF HOIST NOT IN REGULAR USE

If the hoist has been idle for one month or more, perform the inspections listed in paragraph 4-2. If the hoist has been idle more than six months, perform the inspections listed in paragraph 4-3.

4.5 CHAIN INSPECTION

Chain inspection and lubrication are the most important aspects of hoist maintenance. Removal of the chain from the hoist usually is not necessary, but the chain should be run through the hoist enough that every link is made visible for inspection.

- a. Check each link for gouges, nicks, weld spatter, corrosion and distortion.
- b. Inspect each link for wear to the diameter of the link (see Figure 4-1). The nominal link diameter is 0.250 inch for chain on models RA-15, RA-15-2, or RA-20 and 0.312 inch for models RA-30 and above. If the diameter of any link of 0.250 chain is worn to less than 0.200, or the diameter of any link of 0.312 chain is worn to less than 0.275, the entire chain must be replaced.

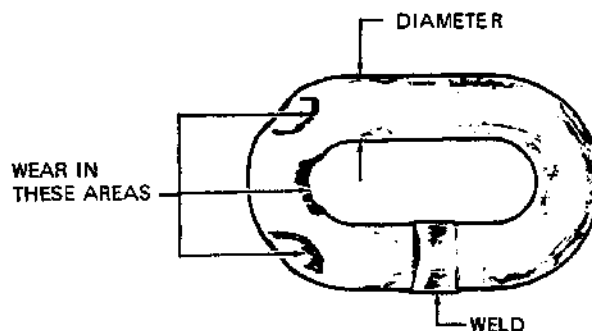

FIGURE 4-1 TYPICAL WEAR ON LINKS

c. 1.) Check the chain for overall wear or stretch by selecting an unworn, unstretched length of chain (at the slack end, for example). Let the chain hang vertically with a light load (about 20 lbs.) on the chain to pull it taut. Use a large caliper to measure the outside length of a convenient number of links (about 12 inches). Measure the same number of links in a used section of chain and calculate the percentage increase in length of the worn chain.

2.) If the length of the worn chain is more than 1½% longer than the unused chain (.015" per inch of chain measured), then the chain should be replaced. If the chain is worn less than 1½%, check it at several more places along its length. If any section is worn more than 1½%, the chain should be replaced.

d. The chain used in this hoist is accurately calibrated to operate over the load sprocket and is very carefully heat treated for maximum wear life and strength.

WARNING

1. Do not weld or use missing links to join hoist load chain.
2. Do not substitute another manufacturer's chain in this hoist.
3. Damage or wear, beyond the stated limits, to any portion of the chain requires that the entire length be replaced.

4.6 HOOK THROAT OPENING

Use Figure 4-2 (below) to check maximum allowable hook throat opening.



HOIST MODEL NO.	REJECT HOOK OPENING	
	TOP HOOK	BOTTOM HOOK
RA-15 & RA-20	1-7/32"	1-7/32"
RA-15-2	1-7/32"	1-7/32"
RA-15-2W	1-7/32"	1-7/32"
RA-30 & RA-40	1-13/32"	1-13/32"
RA-20-2	1-3/4"	1-3/4"
RA-30-2W	1-3/4"	1-3/4"
RA-30-3	2-5/32"	2-5/32"
RA-30-4	2-5/32"	2-5/32"

FIGURE 4-2. HOOK THROAT OPENING

SECTION V MAINTENANCE

5-1 GENERAL

This section provides instructions for the most common routine maintenance and adjustments. Major repairs are not within the scope of this manual and should be referred to qualified service facilities.

5-2 LUBRICATION

Proper lubrication is necessary for a long and relatively trouble-free hoist operation. Refer to the following and to Figure 5-1. Recommended Lubrication Schedule, for lubrication points, type of lubricant and frequency of lubrication.

a. **LOAD CHAIN.** Clean the load chain with a non-acid and non-caustic solvent and coat with SAE 90 gear oil. Wipe excess oil to prevent dripping. If the hoist is used in an atmosphere containing abrasive dust, the chain should be cleaned and oiled more frequently. Never apply grease to the chain.

b. **GEAR AND PINION SHAFT.** After each periodic inspection during reassembly coat teeth of gear and pinion shaft with Coffing Lubricant No. H-7593, or equivalent.

c. **PINION SHAFT SLEEVE BEARING.** After each periodic inspection during reassembly coat bearing with a lightweight oil (SAE 20-30).

d. **BOTTOM HOOK BEARING.** Invert bottom hook and allow a few drops of SAE 20-30 oil to run down the hook shank and into the swivel.

e. **TOP HOOK.** Allow a few drops of SAE 20-30 oil to run down between the housing and hook shank.

f. **BOTTOM BLOCK SHAFT AND BUSHING (Multiple Chained Models).** Disassemble bottom block to the degree required to remove shaft. Lubricate shaft and bushing with SAE 20-30 oil.

FIGURE 5-1 RECOMMENDED LUBRICATION SCHEDULE

COMPONENT	TYPE OF LUBRICANT	TYPE OF SERVICE AND FREQUENCY OF LUBRICATION		
		HEAVY	NORMAL	INFREQUENT
Load Chain	SAE 90 gear oil	Daily	Weekly	Monthly
Gear and Pinion Shaft	D-N No. H-7593 grease Alternate - multi-purpose lithium base bearing grease	At periodic inspection (See Figure 4-4)		
Pinion Shaft Bearing and Handle	D-N No. H-7577 grease Alternate - multi-purpose lithium base bearing grease	At periodic inspection (See Figure 4-4)		
Sheave Bearings Shaft Bearings	SAE 20-30 gear oil	At periodic inspection (See Figure 4-4)		
Bottom Hook Bearing	SAE 20-30 gear oil	Weekly	Monthly	Yearly
Top Hook Thrust Washer	SAE 20-30 gear oil	Monthly	Yearly	Yearly
Bottom Block Shaft And Bushing	SAE 20-30 gear oil	Monthly	Yearly	Yearly

*This lubrication schedule is based on a hoist operating in normal environmental conditions. Hoists operating in adverse atmospheres containing excessive heat, corrosive fumes or vapors, abrasive dust, etc., should be lubricated more frequently.

5-3 CHAIN REPLACEMENT

- a. Cut correct length of chain. **CAUTION:** Do not damage chain during the cutoff process.
- b. Align load sheave pocket with chain shedder per Figure 5-2. Load sheave will not accept chain unless this step is performed.

- c. Feed chain with weld on upstanding link facing away from the load sheave until the flat link is in the pocket per Figure 5-3. Note the chain must be fed into the hoist so that the last link will be in the upstanding position.

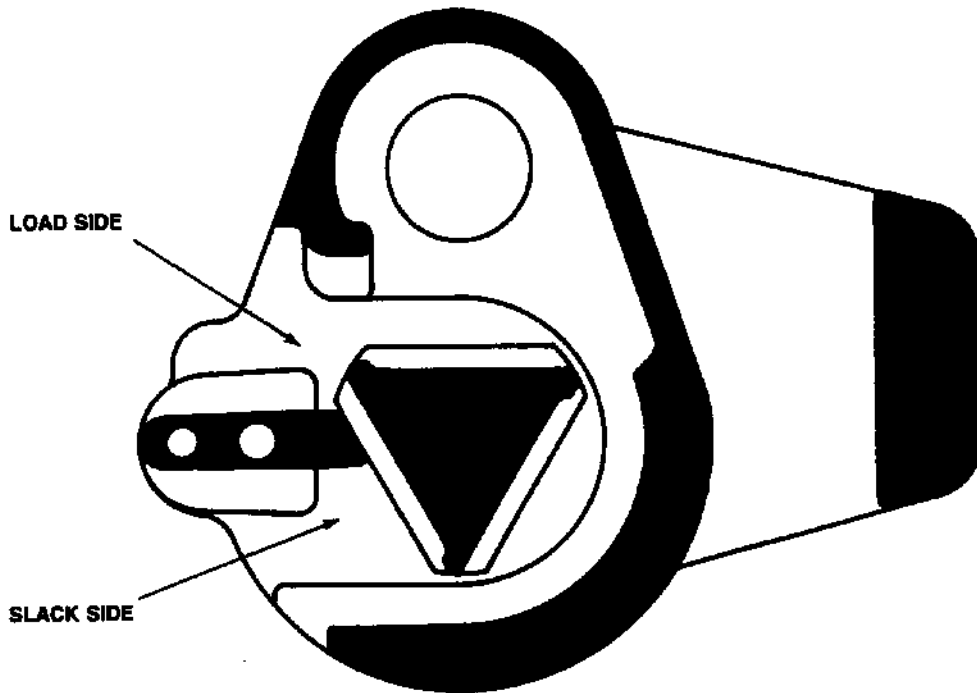

FIGURE 5-2

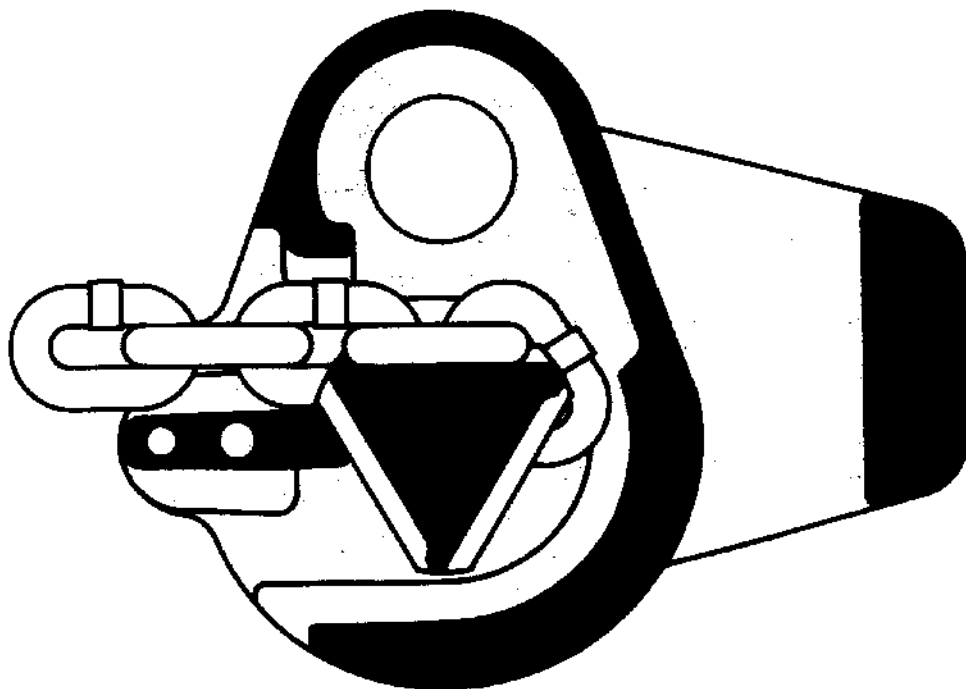
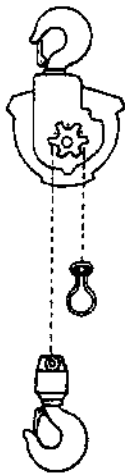
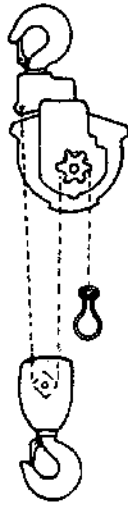

FIGURE 5-3



RA-15



RA-15-2 & RA-15-2W

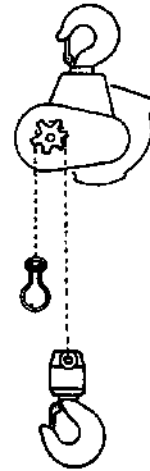

RA-30 & RA-40

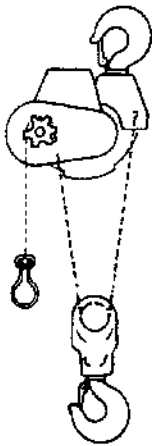

RA-30-2 & RA-30-2W

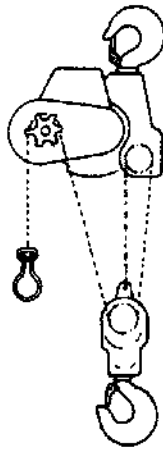

RA-30-3

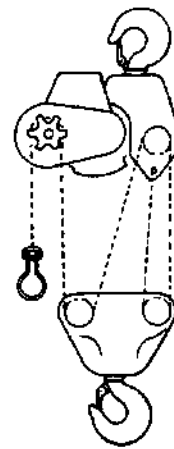

RA-30-4

FIGURE 5-4 CHAIN REEVING

d. Place the control lever in the "Up" position and ratchet lever handle to pull all but thirty inches of chain through the hoist.

e. On single chain models attach the hook and swivel assembly to the load side of the chain. On double chained models pass the load end of the chain through the load block (around the idler sheave). Before securing the end link of the load chain check to see that there are no twists in the chain, and check for proper chain reeving (Figure 5-4). Secure

the end link of the chain to the attachment point using the pin provided.

f. Assemble the end ring to the free end of the chain. Rotate the end link 90° and pass the two ends of the ring through the link. To secure, clinch the ends of the ring together.

g. Check the timing procedure per Section 5-4 and load test the hoist before use.

INSPECTION AND MAINTENANCE CHECK LIST LEVER OPERATED CHAIN HOIST						
TYPE OF HOIST _____			CAPACITY _____			
LOCATION _____			ORIGINAL USE DATE _____			
MANUFACTURER _____			MANUFACTURER'S SERIAL NO. _____			
ITEM	FREQUENCY OF INSPECTION			POSSIBLE DEFICIENCIES	OK	ACTION REQUIRED
	FREQUENT		PERIODIC			
	DAILY	MONTHLY	1-12 MO.			
Load Chain	*	*	*	Inadequate lubrication, excessive wear or stretch, cracked, damaged or twisted links, corrosion or foreign substance		
Hooks	*	*	*	Excessive throat opening, bent or twisted more than 10 degrees, damaged hook latch, wear, chemical damage, worn hook bearing. Cracks (use dye penetrant, magnetic particle or other suitable detection method)		
Hook Retainers			*	Worn or damaged nuts, pins, washers, collars used to secure hook in load block or housing		
Ratchet Handle Pawl & Load Pawl			*	Wear, cracks, broken teeth Wear, cracks or binding		
Pawl Springs			*	Breaks, corrosion, loss of tension		
Retaining Rings			*	Missing or loss of retention		
Reverse Ring Spring			*	Breaks, corrosion or stretch		
Pawl Stud			*	Excessive wear, pawl retention, looseness		
Sheave, Pinion Shaft, Chain Attachments			*	Distortion, cracks, excessive wear, damaged threads, build up of foreign substances		
Gearing			*	Inadequate lubrication, distortion, cracks, worn or broken teeth		
Bearings, Shafts			*	Inadequate lubrication, distortion, cracks, excessive wear		
Housing, Load Block, Outtrigger, Hook Swivels			*	Cracks, distortion, loose bolts, nuts or rivets. Internal build up of foreign substances		
Nuts, Bolts, Rivets			*	Looseness, stripped or damaged threads		
Supporting Structure			*	Damage or wear which restricts ability to support imposed loads		
Capacity Plate & Decals			*	Missing, damaged or illegible		
NOTE: Refer to Maintenance and Inspection Sections of the Hoist Manual for further details.						
FREQUENCY OF INSPECTION:						
Frequent - Indicates items requiring inspection daily to monthly. Daily inspections may be performed by the operator if properly designated.						
Periodic - Indicates items requiring inspection monthly to yearly. Inspections to be performed by or under the direction of a properly designated person. The exact period of inspection will depend on frequency and type of usage. Determination of this period will be based on the user's experience. It is recommended that the user begin with a monthly inspection and extend the periods to quarterly, semi-annually or annually based on his monthly experience.						

FIGURE 5-5 INSPECTION AND MAINTENANCE CHECK LIST

INSPECTOR'S REPORT	
ITEM	REMARKS (LIST DEFICIENCIES AND RECOMMENDED ACTION)
INSPECTOR'S SIGNATURE	DATE INSPECTED
	APPROVED BY
	DATE

FIGURE 5-6 RECOMMENDED INSPECTORS REPORT

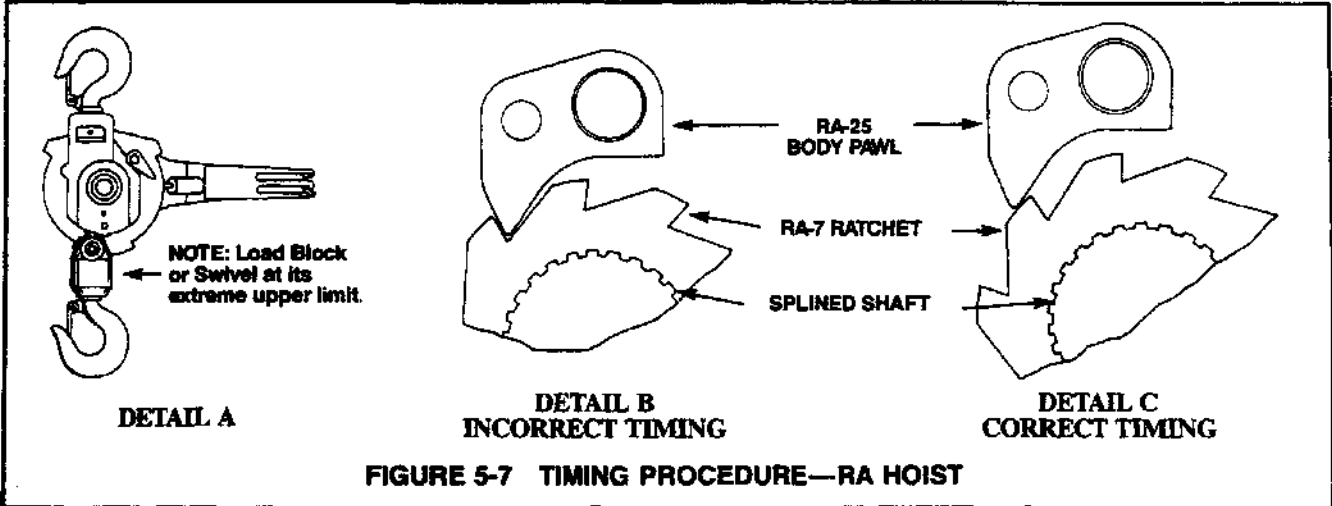

FIGURE 5-7 TIMING PROCEDURE—RA HOIST

5-4 TIMING PROCEDURE

After assembly of chain and hook block, the RA hoist must be "timed" in order that it will "lower" when the hook block is drawn up tight to the underside of the hoist body. The timing procedures are as follows:

- a. Raise the hook block until it is tight against the hoist body (Detail A).
- b. Unscrew the handle retaining screw and remove the handle, which will expose the ratchet and pawl mechanism.
- c. If body pawl (RA-25) is engaged with RA-7 ratchet as shown in Detail B with the control lever in the "up" position, the hoist is improperly timed and will not lower.

- d. If pawl is engaged, remove the RA-7 ratchet from the splined portion of the shaft. Hold the spring loaded pawl out of engagement and rotate the ratchet from one spline tooth to the next until the tip of the body pawl rests on top of the ratchet tooth, approximately 1/8" (minimum) from tip of ratchet tooth as shown in Detail C.
- e. Check for proper timing by replacing operating handle and placing the control lever in the "down" (DN) position. Apply downward pressure on the hook or hook block and ratchet the handle a few strokes. If hook block moves downward, the hoist is properly timed.

SECTION VI ILLUSTRATED PARTS LIST

6-1 GENERAL

The following exploded drawing provides a complete list of parts used in the standard RA Series hoist (shown in Table 1). Since different models and capacities are covered by this manual the index number and parts list will show each different part number with sufficient information to allow the selection of the correct part number.

6-2 HOW TO USE THE PARTS LIST

Exploded illustrations of the RA Series hoist follows. The number adjacent to each part is the index number. Keyed to

this index number on the following page is the part name, quantity required and the part number.

6-3 HOW TO ORDER REPLACEMENT PARTS

When ordering parts or requesting information concerning your RA hoist, always include the hoist Model Number and Serial Number with the Index and Part Numbers required. NOTE: Repair parts are available only from Coffing authorized repair facilities. It is recommended that repair parts orders be directed to the authorized repair facility nearest you.

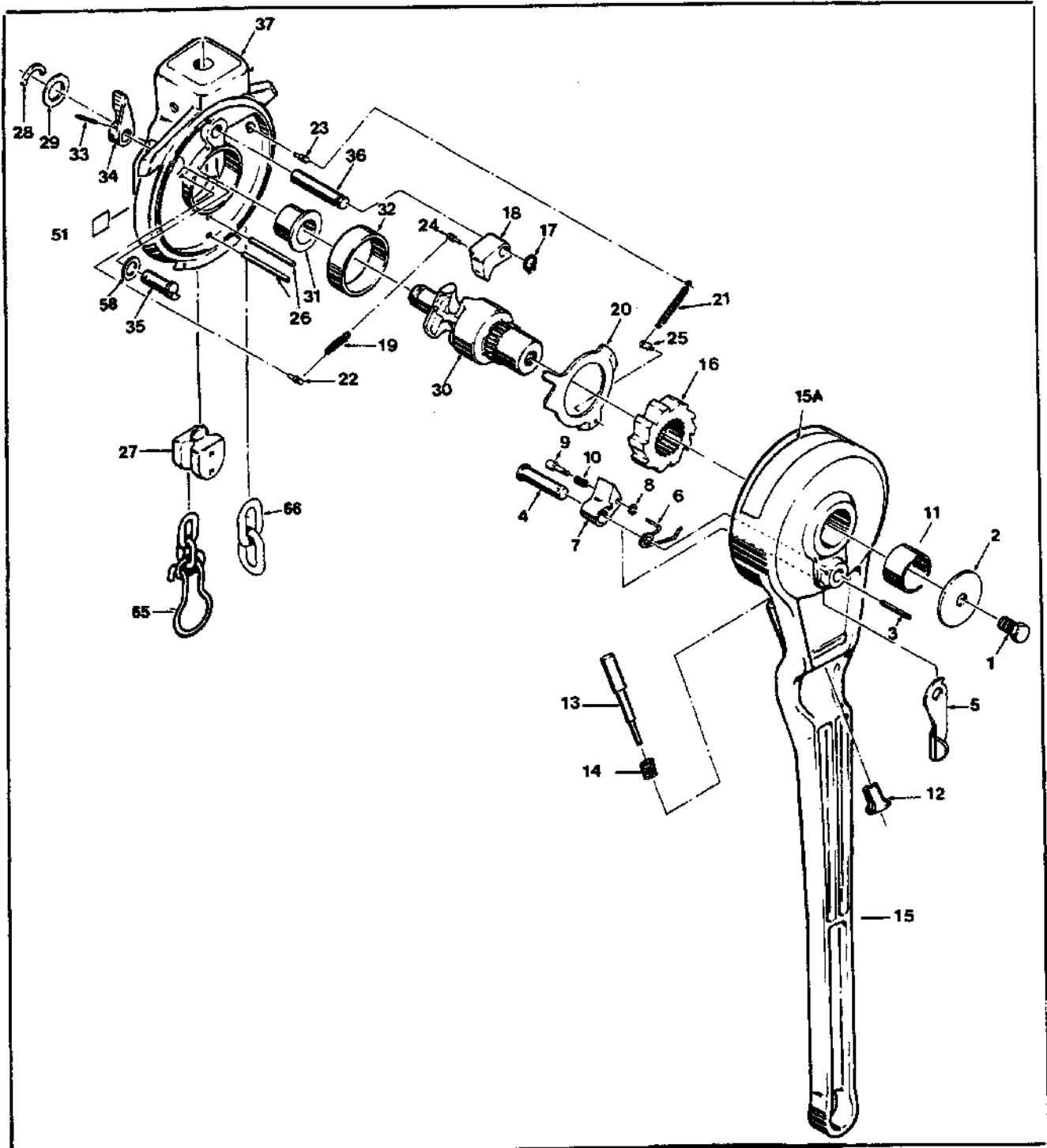

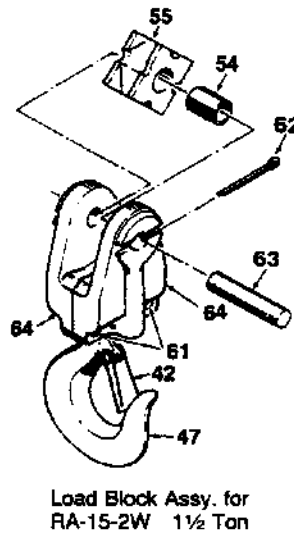
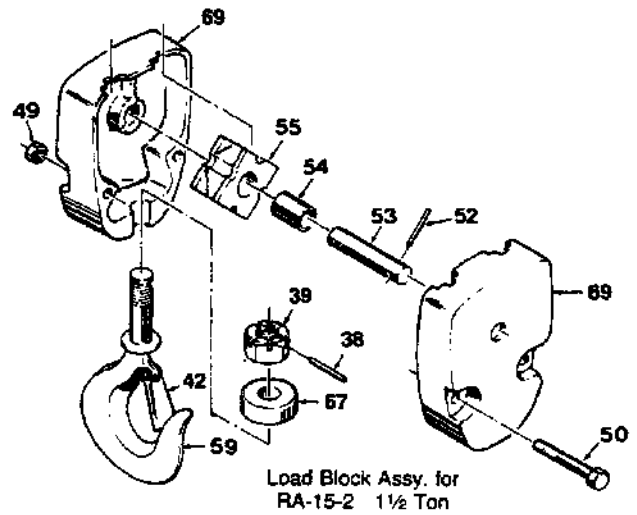
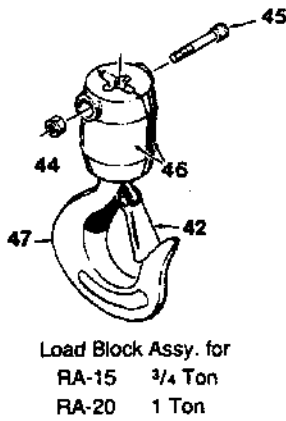
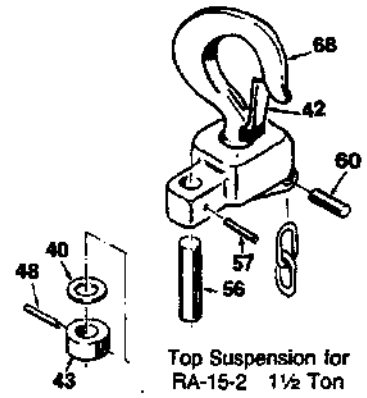
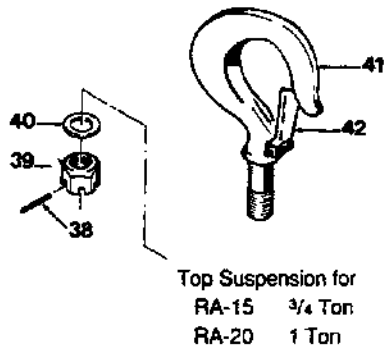

FIGURE 6-2 SUSPENSION ASSEMBLIES FOR RA-15 & RA-20 SERIES

PARTS LIST FOR RA-15 & RA-20 SERIES

Index No.	Part Name	Qty. Req.	Part No.	Index No.	Part Name	Qty. Req.	Part No.
1	Handle Retainer Screw	1	H-2948P	50**	Screw	2	H-2403P
2	Handle Washer	1	RA-251	51	Nameplate	1	675K71 (3/4 ton)
3**	Pin	1	H-5232	51	Nameplate	1	675K70 (1 1/2 ton)
4**	Handle Pawl Pin	1	RA-105	51	Nameplate	1	RLY675-2 (1 ton)
5**	Handle Pawl Lever	1	RA-253	52**	in	2	H-5234
6**	Handle Pawl Spring	1	RA-311	53**	Shaft	1	JF-122-1
7**	Handle Pawl	1	RA-4-1	54**	Bearing	1	530J33
8**	Trip Pin Ring	1	H-5567	55*	Sheave	1	B-57-1A
9**	Trip Pin	1	RA-103-1	56	Coupling Shaft	1	MA-106
10**	Trip Spring	1	RA-341	57	Pin	1	H-5129
11**	Bearing	1	RA-530	58	Wave Washer	1	RA-313
12**	Stop Pin Button	1	RA-101	59**	Bottom Hook (Includes Index No. 42)	1	3K6S
13**	Stop Pin	1	RA-100	60	Pin	1	H-5123
14**	Stop Pin Spring	1	RA-340	61**	Rivet	2	H-4562
15**	Handle	1	RA-1-1	62**	Cotter Pin	2	H-5029-P
15A	Warning Decal	1	687K6	63**	Idler Pin	1	HJ-28-A
16	Ratchet	1	RA-7	64**	Block Frame	2	HJ-30
17	Ring	1	H-5518	65	End Ring	1	MA-75
18*	Load Pawl	1	RA-25-1	66	Load Chain	1	JL-19B
19	Load Pawl Spring	1	RA-310	67**	Thrust Bearing	1	JF-510
20*	Reverse Ring	1	RA-10	68	Top Hook and Outtrigger Assembly (Includes Index No. 42)	1	MA-915-17
21	Reverse Ring Spring	1	SP-10S	69**	Load Block Frame	2	JF-30
22**	Spring Anchor Pin	1	A-18-A	70†	Handle Pawl Assembly (Includes Index 7-10)	1	RA-901
23**	Spring Anchor Pin	1	A-18-B	71†	Load Pawl Assy. (Includes Index No. 24)	1	RA-902
24**	Spring Anchor Pin	1	H-5214	72†	Handle Assy. (Includes Index Nos. 3 thru 15)	1	RA-908-1
25**	Spring Anchor Pin	1	RA-104	73†	Reversde Ring Assy. (Includes Index No. 25)	1	RA-911
26	Shedder Pin	2	H-5127	74†	Housing Bearing and Pins (Includes Index Nos. 22, 23, 31, 32, 36, 37)	1	RA-952
27	Shedder	1	MA-37	75†	Bottom Hook Assy. (Includes Index Nos. 39, 38, 67, 59)	1	3KG6
28	Ring	1	H-5506	76†	Load Block Sheave and Beaing (Includes Index Nos. 54, 55)	1	BB-57-I
29	Rethining Washer	1	MA-250	77†	Load Block Shaft Assy. (Includes Index Nos. 52, 53, 76)	1	JF-917
30	Load Sheave	1	RA-16-1	78†	Load Block Assy. (Includes Index Nos. 49, 49A, 50, 69, 75, 77)	1	JF-914-7
31**	Bearing	1	RA-534	79†	Load Block Assy. (Includes Index Nos. 44, 45, 46, 47)	1	MA-913-20
32**	Bearing	1	MA-531	80†	Load Block Assy. (Includes Index Nos. 47, 61, 62, 63, 64, 76)	1	BBB-57-2
33	Pin	1	H-5240				
34	Reverse Cam Lever	1	RA-32				
35	Reverse Ring Cam	1	RA-102				
36**	Load Pawl Pin	1	RA-26				
37*	Housing	1	RA-18				
38**	Roll Pin	1	H-5251				
39**	Nut	1	H-3986-P				
40	Hook Washer	1	JF-260				
41	Top Hook (Includes Index No. 42)	1	MA-3-10S				
42**	Latch Kit	2	H-7540				
43	Hook Collar	1	JF-108				
44**	Nut	1	H-3473P				
45**	Swivel Screw	1	JF-700				
46**	Swivel Frame	2	MA-20-1 (3/4 ton)				
46	Swivel Frame	2	MA20-3 (1 ton)				
47**	Hook (Includes Index No. 42)	1	3K8S				
48	Pin	1	H-5122				
49**	Nut	2	H-3473P				
49A**	Lock Washer	2	H-4063P				

* Not sold separately as a repair part. If replacement is required, procure the appropriate following assembly.

** Sold individually as a repair part and as a part of the appropriate following assembly.

† Assembly not indexed on illustration.

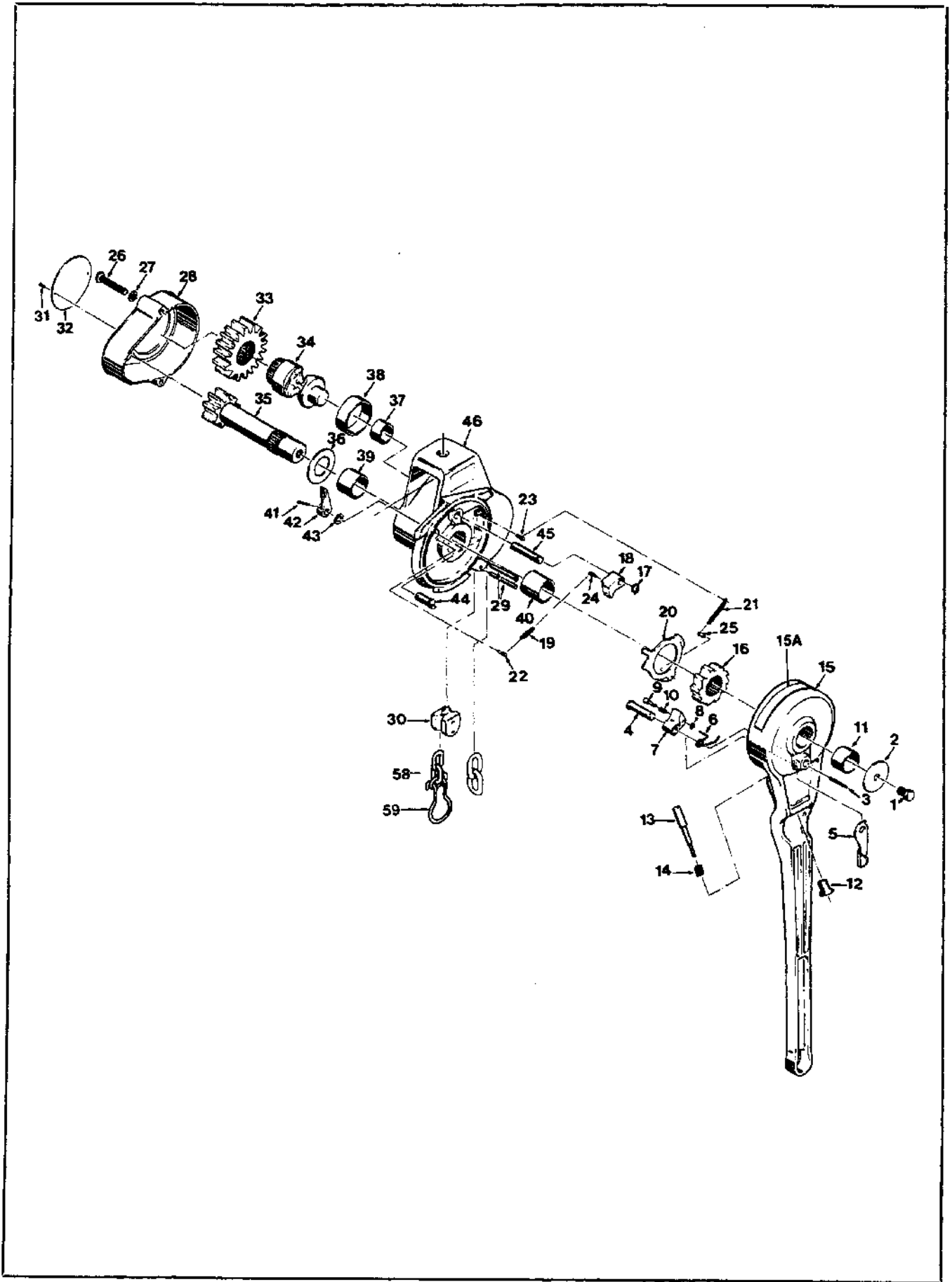
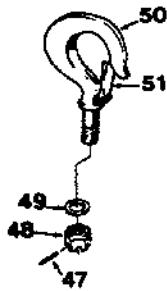
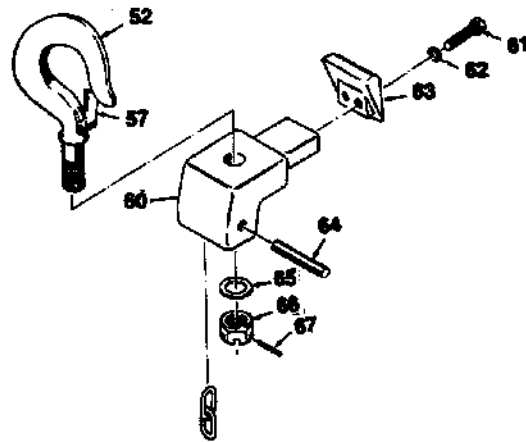

FIGURE 6-3 EXPLODED ILLUSTRATION OF RA-30 & RA-40 BASIC HOIST



Load Block Assy. for
 RA-30 1½ Ton
 RA-40 2 Ton



Top Suspension for
 RA-30-2 3 Ton

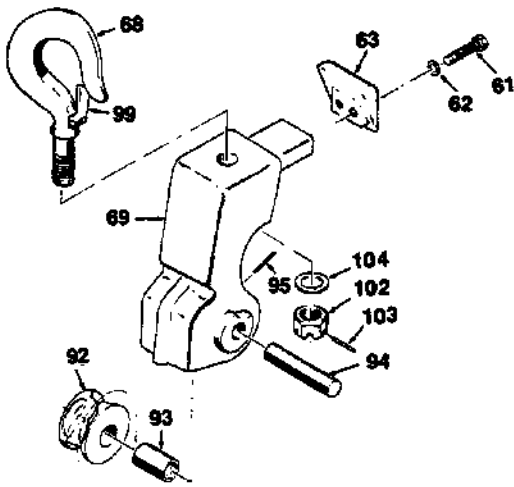

Top Suspension for
 RA-30-3 4½ Ton

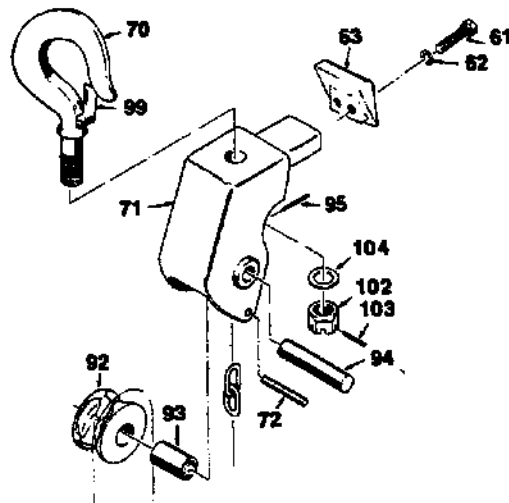

Top Suspension for
 RA-30-4 6 Ton

FIGURE 6-4 TOP SUSPENSION ASSEMBLIES FOR RA-30 & RA-40 SERIES

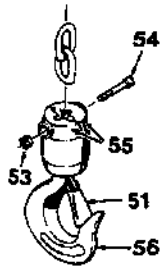

Top Suspension for
RA-30 1½ Ton
RA-40 2 Ton

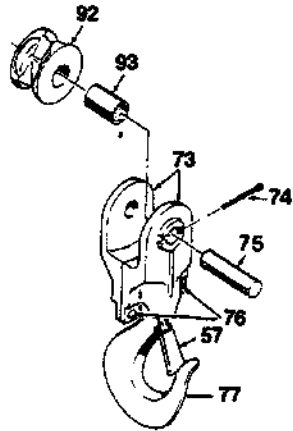

Load Block Assy. for RA-30-2W

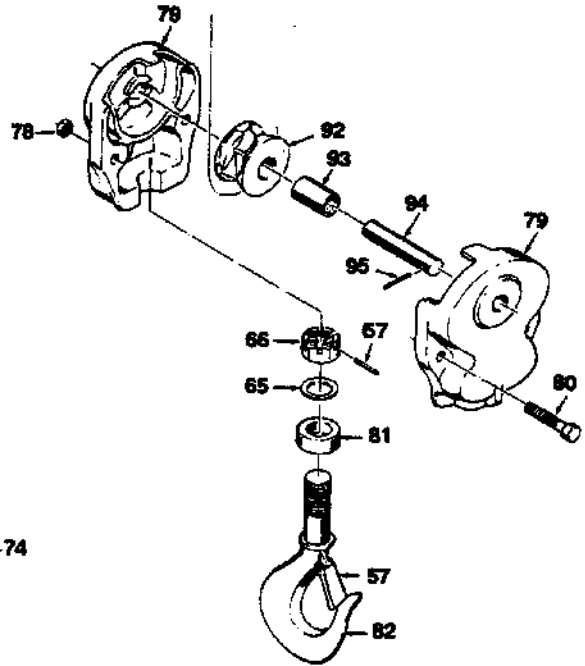

Load Block Assy. for
RA-30-2 3 Ton

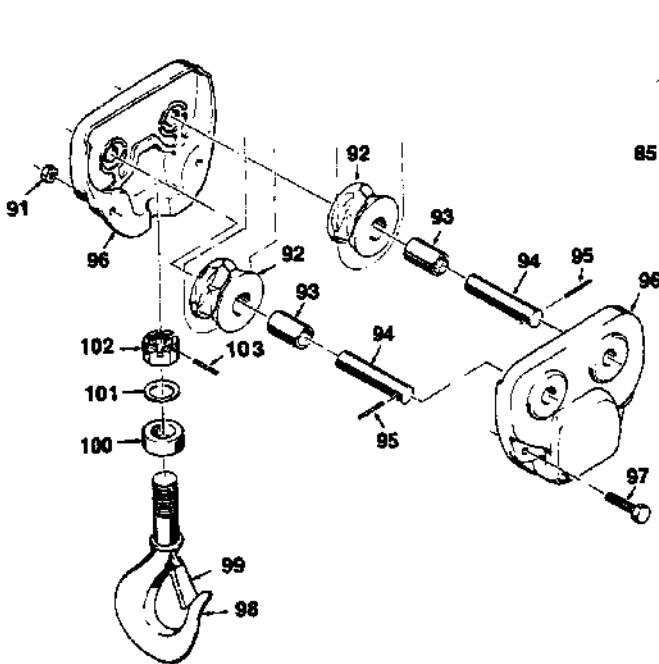

Load Block Assy. for
RA-30-4 6 Ton

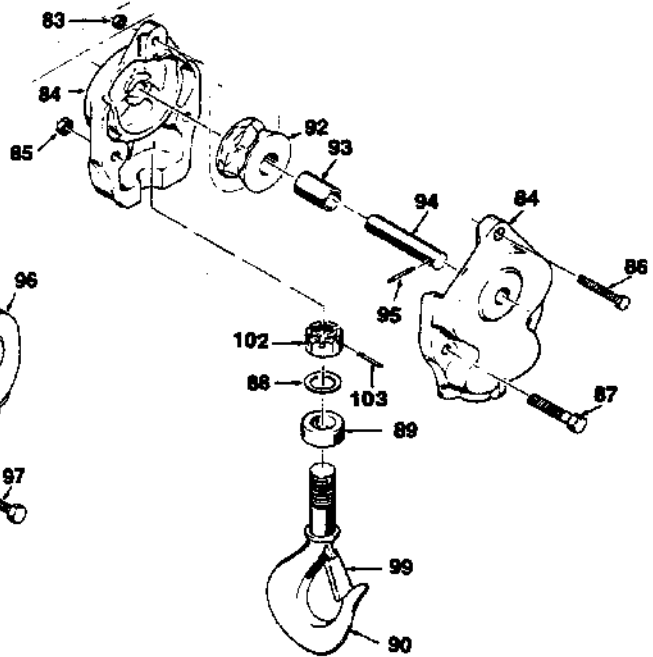

Load Block Assy. for
RA-30-3 4½ Ton

FIGURE 6-5 BOTTOM SUSPENSION ASSEMBLIES FOR RA-30 & RA-40 SERIES

PARTS LIST FOR RA-30 & RA-40 SERIES

Index No.	Part Name	Qty. Req.	Part No.	Index No.	Part Name	Qty. Req.	Part No.
1	Handle Retainer Screw	1	H-2948P	50	Top Hook (Includes Index No. 51)	1	3K10S
2	Handle Washer	1	RA-251	51	Latch Kit	1	H-7540
3**	Pin	1	H-5232	52**	Top Hook (Includes Index No. 57)	1	SHL-5
4**	Handle Pawl Pin	1	RA-105	53**	Nut	1	H-3473-P
5**	Handle Pawl Lever	1	RA-253	54**	Swivel Screw	1	MA-718-2
6**	Handle Pawl Spring	1	RA-311	55**	Swivel Frame	2	MA-20-2(1 1/2 ton)
7**	Handle Pawl	1	RA-4-1	55	Swivel Frame	2	MA20-4 (2 ton)
8**	Trip Pin Ring	1	H-5567	56**	Hook (Includes Index No. 57)	1	3K9S
9**	Trip Pin	1	RA-103-1	57**	Latch Kit	2	H-7544
10**	Trip Spring	1	RA-341	58	Load Chain	1	C-19-10
11**	Bearing	1	RA-530	59	End Ring	1	MA-75
12**	Stop Pin Button	1	RA-101	60**	Outrigger	1	MA-42
13**	Stop Pin	1	RA-100	61	Screw	2	H-2423P
14**	Stop Pin Spring	1	RA-340	62	Lock Washer	2	H-4136
15*	Handle	1	RA-1-1	63	Keeper	1	MA-43
15A	Warning Decal	1	687K6	64	Pin	1	H-5131
16	Ratchet	1	RA-7	65**	Hook Washer	2	CB-253
17	Ring	1	H-5518	66**	Nut	2	H-3922-P
18*	Load Pawl	1	RA-25-1	67**	Pin	2	H-5243
19	Load Pawl Spring	1	RA-310	68**	Top Hook (Includes Index No. 99)	1	SHL-7
20*	Reverse Ring	1	RA-10-2	69**	Outrigger	1	MA-42-1
21	Reverse Ring Spring	1	SP-10-S	70**	Top Hook (Includes Index No. 99)	1	SHL-9
22**	Spring Anchor Pin	1	A-18-B	71**	Outrigger	1	MA-42-2
23**	Spring Anchor Pin	1	A-18-A	72	Pin	1	H-5131
24**	Spring Anchor Pin	1	H-5214	73**	Load Block Frame	2	HJ-130
25**	Spring Anchor Pin	1	RA-104	74**	Cotter Pin	2	S2-19
26	Screw	2	H-1886-P	75**	Load Block Shaft	1	F-28-A-1
27	Lock Washer	2	H-4138	76**	Rivet	2	H-4551
28	Gear Cover	1	MA-11-1	77**	Hook (Includes Index No. 57)	1	3K36S
29	Shedder Pin	2	H-5126	78**	Nut	2	H-3964P
30	Sheader	1	MA-37-1	79**	Load Block Frame	2	MA-29
31	Drive Screw	2	H-2864-P	80**	Screw	2	H-2423P
32	Capacity Plate (1 1/2 ton)	1	MA-675	81**	Thrust Bearing	1	CB-510
32	Capacity Plate (2 ton)	1	CB-675	82**	Bottom Hook (Includes Index No. 57)	1	SHL-6
32	Capacity Plate (3 ton)	1	CB-675-3	83	Nut	1	H-3964P
32	Capacity Plate (4 1/2 ton)	1	MA-675-1	84**	Load Block Frame	2	MA-29-1
32	Capacity Plate (6 ton)	1	CB-675-4	85**	Nut	2	H-3965P
33	Gear	1	RA-480	86	Dead End Screw	1	MA-700-1
34	Load Sheave	1	MA-16-5	87**	Screw	2	H-2411-P
35	Pinion Shaft	1	RA-483	88**	Hook Washer	1	CB-252-2
36	Thrust Washer	1	MA-253	89**	Thrust Bearing	1	CB-511
37**	Bearing	1	MA-532	90**	Bottom Hook (Includes Index No. 99)	1	SHL-8
38**	Bearing	1	MA-531-1	91**	Nut	2	H-3966P
39**	Bearing	1	MA-533	92*	Sheave	2	SP-28
40**	Bearing	1	RA-533	93**	Bearing	2	A-28-B
41	Pin	1	H-5240	94**	Load Block Shaft	2	MA-101
42	Reverse Cam Lever	1	RA-32-1				
43	Wave Washer	1	RA-313				
44	Reverse Ring Cam	1	RA-102				
45**	Load Pawl Pin	1	RA-26				
46*	Housing	1	RA-18-1				
47	Pin	1	H-5232				
48	Nut	1	H-3921-P				
49	Hook Washer	1	JF-265				

* Not sold separately as a repair part. If replacement is required, procure the appropriate following assembly.

** Sold individually as a repair part and as a part of the appropriate following assembly.

† Assembly not indexed on illustration.

Index No.	Part Name	Qty. Req.	Part Number	Index No.	Part Name	Qty. Req.	Part Number
95**	Pin	2	H-5234	112†	Load Block Shaft Assembly (Includes Index Nos. 94, 95)	1	MA-903
96**	Load Block Frame	2	MA-29-2	113†	Bottom Hook Assembly (Includes Index Nos. 65, 66, 67, 81, 82)	1	MA-912-2
97**	Screw	2	H-2419P	114†	Outrigger Assembly (Includes Index Nos. 52, 60, 65, 66, 67)	1	MA-915-5
98**	Bottom Hook (Includes Index No. 99)	1	SHL-10	115†	Load Block Assembly (Includes Index Nos. 78, 79, 80, 95, 94)	1	MA-914-4
99**	Latch Kit	2	H-7545	116†	Load Block Assembly (Includes Index Nos. 73, 74, 75, 76, 111)	1	SSP-30SH
100**	Thrust Bearing	1	CB-511-1	117†	Bottom Hook Assembly (Includes Index Nos. 88, 89, 90, 102, 103)	1	MA-912-3
101**	Bearing Adapter	1	MA-103	118†	Triple Chain Load Block Assembly (Includes Index Nos. 84, 85, 87, 94, 95)	1	MA-914-5
102**	Nut	2	H-3924P	119†	Outrigger Assembly (Includes Index Nos. 95, 102, 103, 104)	1	MA-915-6
103**	Pin	2	H-5235	120†	Bottom Hook Assembly (Includes Index Nos. 101, 102, 103)	1	MA-912-4
104**	Hook Washer	1	CB252-1	121†	Outrigger Assembly (Includes Index Nos. 95, 102, 103, 104)	1	MA-915-7
105†	Handle Pawl Assembly (Includes Index Nos. 7 thru 10)	1	RA-901	122†	Load Block Assembly (Includes Index No. 91, 94, 95, 96, 97)	1	MA-914-6
106†	Load Pawl Assembly (Includes Index Nos. 18 thru 24)	1	RA-902				
107†	Handle Assembly (Includes Index Nos. 3 thru 15)	1	RA-908-1				
108†	Reverse Ring Assembly (Includes Index Nos. 20, 25)	1	RA-911-2				
109†	Housing, Bearing and Pins Assembly (Includes Index Nos. 22, 23, 37 thru 40, 45 & 46)	1	RA-952-3				
110†	Load Block Assembly (Includes Index Nos. 53 thru 56)	1	MA-913-21				
111†	Load Block Sheave and Bearing Assembly (Includes Index Nos. 92, 93)	1	SSP-28				

* Not sold separately as a repair part. If replacement is required, procure the appropriate following assembly.

** Sold individually as a repair part and as a part of the appropriate following assembly.

† Assembly not indexed on illustration.

DO'S AND DO NOT'S

Manually Lever Operated Chain Hoists

The following warnings and operating practices are intended to avoid unsafe hoisting practices which might lead to personal injury or property damage.

These recommendations apply to all manually lever operated chain hoists used for lifting, pulling, and tensioning type applications.

WARNING: TO AVOID INJURY

1. **DO** read the Hoist Manufacturer's Operating and Maintenance Instructions.
2. **DO** be familiar with operating controls, procedures, and warnings on the unit.
3. **DO** make sure that the unit is securely attached to a suitable support before applying load.
4. **DO** maintain firm footing or be otherwise secured when operating unit.
5. **DO** make sure that load slings or other approved sling attachments are properly sized and seated in the hook saddle.
6. **DO** make sure the hook latches, if used, are closed and not supporting any part of the load.
7. **DO** make sure that load is free to move and will clear all obstructions.
8. **DO** take up slack carefully, check load balance, move the load a few inches, and check load holding action before continuing.
9. **DO** make sure all persons stay clear of the supported load.
10. **DO** avoid swinging of load or load hook.
11. **DO** protect load chain from weld spatter or other damaging contaminants.
12. **DO** avoid lever "fly-back" by keeping a firm grip on the lever until operating stroke is completed and the lever is at rest.
13. **DO** promptly report any malfunction, unusual performance, or damage of the unit.
14. **DO** inspect unit regularly, replace damaged or worn parts, and keep appropriate records of maintenance.
15. **DO** use the Hoist Manufacturer's recommended parts when repairing unit.
16. **DO** use hook latches wherever possible.
17. **DO** apply lubricant to load chain as recommended by the Hoist Manufacturer.

"DO's and Do Not's" reprinted with the permission of the Hoist Manufacturer's Institute.

18. **DO NOT** lift or pull more than rated load.
19. **DO NOT** use the hoist load limiting or warning device to measure the load.
20. **DO NOT** use damaged unit or unit that is not working correctly.
21. **DO NOT** use unit with twisted, kinked, damaged, or worn chain.
22. **DO NOT** apply a load unless chain is properly seated in chain wheel(s) or sprocket(s).
23. **DO NOT** use load chain as a sling or wrap chain around a load.
24. **DO NOT** apply a load if any binding prevents equal loading on all load supporting chains.
25. **DO NOT** apply the load to the tip of the hook.
26. **DO NOT** operate unit when it is restricted from adjusting itself to form a straight line with the direction of loading.
27. **DO NOT** operate except with hand power.
28. **DO NOT** permit more than one operator to pull on lever at the same time.
29. **DO NOT** operate with any lever extension (cheater bar).
30. **DO NOT** allow your attention to be diverted from operating the unit.
31. **DO NOT** operate unit beyond limits of load chain travel.
32. **DO NOT** attempt to "free chain" unit with any load applied.
33. **DO NOT** use hoist to lift, support, or transport people.
34. **DO NOT** lift loads over people.
35. **DO NOT** leave a load supported by the unit unattended unless specific precautions have been taken.
36. **DO NOT** allow unit to be subjected to sharp contact with other units, structures or objects through misuse.
37. **DO NOT** allow the chain or hook to be used as a ground for welding.
38. **DO NOT** allow the chain or hook to be touched by a live welding electrode.
39. **DO NOT** remove or obscure the warnings on the unit.
40. **DO NOT** adjust or repair a unit unless qualified to perform such maintenance.
41. **DO NOT** attempt to lengthen the load chain or repair damaged load chain.

WARNING: The equipment shown in this manual is intended for industrial use only and should not be used to lift, support, or otherwise transport people, or to suspend unattended loads over people.

Coffing Hoists • Country Club Road • P.O. Box 779 • Wadesboro, NC 28170 USA
Customer Service: Tel. (800) 477-5003 (704) 694-2156 • FAX (800) 374-6853 (704) 694-6829

COFFING® HOISTS

RA-680-3
2C 2/00
Printed in USA
© 2000 Coffing Hoists